

KRACHT

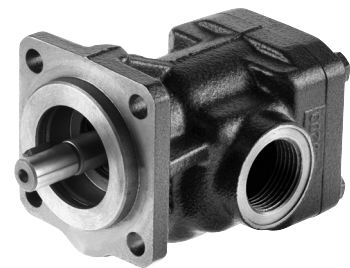

Transfer Gear Pumps

KF 4...80

Contents

Technical Data

	Page
Applications / Suitable fluids	4
Construction	5
Variants / Direction of rotation	6
Materials / Characteristics	7
Shaft end seals / Variants	8 – 9
Version noise optimized	10
Type key	11
Technical data	12
Discharge flow / Input power	13 – 14
Input power	15

Dimension Sheets

Flange-mounting version with pipe thread	Nom. displacement 4 – 25	16
Flange-mounting version with SAE 3/4 and 1-connection	Nom. displacement 4 – 25	17
Flange-mounting version with SAE 1 1/2-connection	Nom. displacement 32 – 80	18
Flange-mounting version with SAE 2-connection	Nom. displacement 50 – 80	19
Pump with mounting angle, pipe thread	Nom. displacement 4 – 25	20
Pump with mounting angle, SAE 3/4 and 1-connection	Nom. displacement 4 – 25	21
Pump with mounting angle, SAE 1 1/2-connection	Nom. displacement 32 – 80	22
Pump with mounting angle, SAE 2-connection	Nom. displacement 50 – 80	23
Flange-mounting version with universal arrangement	Nom. displacement 4 – 25	24
Flange-mounting version with universal arrangement	Nom. displacement 32 – 80	25
Accessory couplings		26
Bell housing	Nom. displacement 4 – 25	27
Bell housing	Nom. displacement 32 – 80	28
Motor-pump assemblies with pipe thread	Nom. displacement 4 – 25	29 – 30
Motor-pump assemblies with SAE 3/4 and 1-connection	Nom. displacement 4 – 25	31 – 32
Motor-pump assemblies with SAE 1 1/2-connection	Nom. displacement 32 – 80	33 – 34
Motor-pump assemblies with SAE 2-connection	Nom. displacement 50 – 80	35 – 36
Threaded flange G-SAE 3/4 / Welding flange S-SAE 3/4		37
Threaded flange G-SAE 1 / Welding flange S-SAE 1		38
Threaded flange G-SAE 1 1/2 / Welding flange S-SAE 1 1/2		39
Threaded flange G-SAE 2 / Welding flange S-SAE 2		40
Accessory liquid seal		41

Applications, Suitable Fluids

Applications

Centrifuge construction,
Coating machines, Compressors
Engine construction
Filling stations, Filter systems
Generator construction
Heat transfer systems, Heavy electrical machines
Lubricant manufacturers, Lubricating oil systems
Machine-building industry, Machine tools,
Manufacture of apparatus,
Marine engine construction,
Metal-forming machines, Metering systems
Paint industry, Plain metal bearing production,
Printing machines, PUR machinery
Refrigerators, Rubber and tire manufacturing
Tank plant construction,
Transmission building
Turbine construction
Vacuum machinery
Waste oil - disposal
 - transport
 - treatment

Suitable fluids

Adhesives, Antifreeze
Bore oils
Cutting oils
Diesel oils, Drawing compound
Emulsions
Fuel oils, L, EL, H
Gear oils, Grease
Hardening oils, Heat transfer media,
Heavy oils, Hydraulic fluids
Isocyanate
Lubricating oils, Lacquers
Motor oils
Paint, Paraffins, Plastics, Polyols
Printing inks, Processing oils
Resins, Rolling oils
Waste oils, Waxes

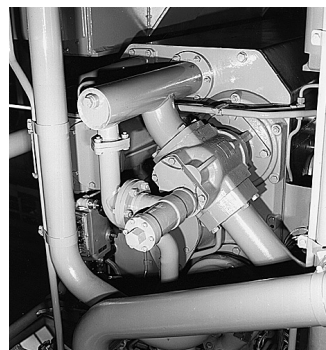
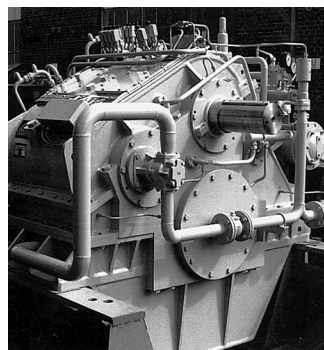
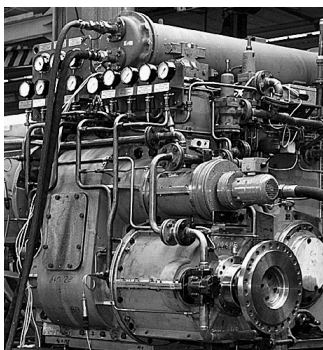
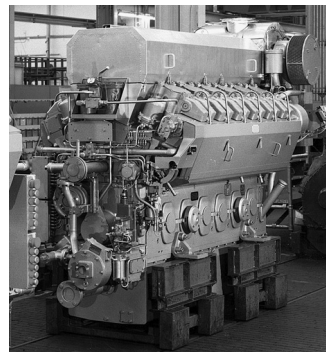

Construction

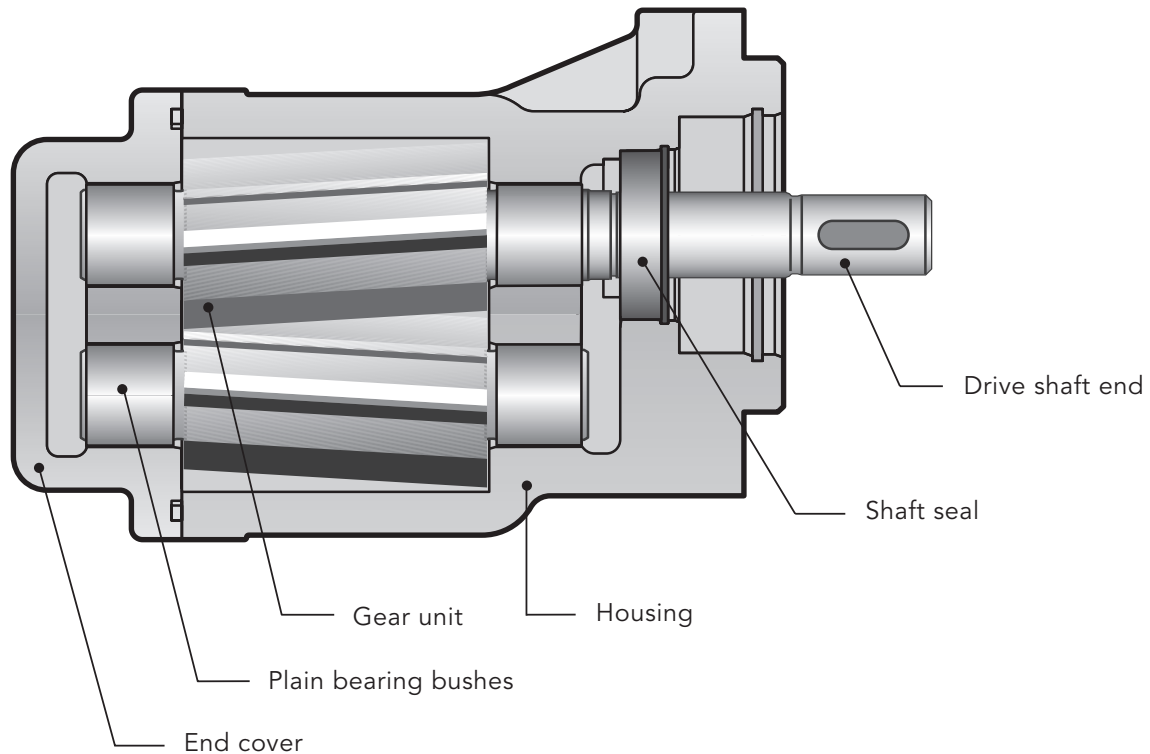

Produkt Features

Transfer gear pumps KF gear pumps are used for pumping a wide variety of fluids.

Transfer gear pumps KF gear pumps are distinguished especially by their wide range of variants which are assembled as required on the modular principle and also permit subsequent upgrade.

The pumps are also suitable for media with low lubricating properties.

The standard housing sections are of grey cast iron.

The gear units are manufactured from high-strength case-hardening steel, hardened and mounted in special multi-compound plain bearing bushes.

The standard drive shaft is sealed by rotary shaft lip-type seal.

All pump sizes incorporate helical tooth system.

This feature, combined with special gear geometry, results in extremely low noise levels and reduced pressure pulsation.

Operating Notes

- The fluids should ensure a certain minimum lubricating properties, should not contain solids and should be chemically compatible.
- Avoid dry operation.
- The pumps may only be operated in the specified direction of rotation, as otherwise the shaft seal will be destroyed.
- In order to prevent excessive overpressure, a safety valve should be provided in the system or on the pump.
- The pressure relief valve attached to the pump may only be used as safety valve for short-term operation.
- To drain off a partial discharge flow over a prolonged period, a separate pressure relief valve with return line must be inserted in the reservoir.
- A separate pressure relief valve with return line to the reservoir must be foreseen, if a partial discharge flow has to be drained over a prolonged period.

Variants

- Sealing of the drive shaft:
 - Rotary shaft lip-type seal
 - Double rotary shaft lip-type seal (Quench)
 - Mechanical seal
- Outboard bearing to take up input drive-side radial load
- Pressure relief valve as safety valve for pump and system
- Uniform discharge flow direction with changing direction of rotation by means of flange-mounting valve combination (universal device).

Special Design

Various shafts ends and gear units, as well as flange mounted versions, bearing alternatives, multi-stage pump combinations for your special application are available on request.

Our Sales engineers will be pleased to advise you.

Accessories

- Connecting flanges
- Couplings
- Bell housing
- Tank for liquid seal liquids
- Attenuation elements on request

ATEX

We offer numerous transfer gear pumps from the KF 4...80 series in ATEX versions. Please ask for our ATEX product catalogue.

Direction of Rotation

The following should be note for direction of rotation:

- when looking at the pump shaft end, the direction of pumping is from left to right if the shaft rotates clockwise.
- when looking at the pump shaft end, the direction of pumping is from right to left if the shaft rotates counterclockwise.

Without pressure relief valve

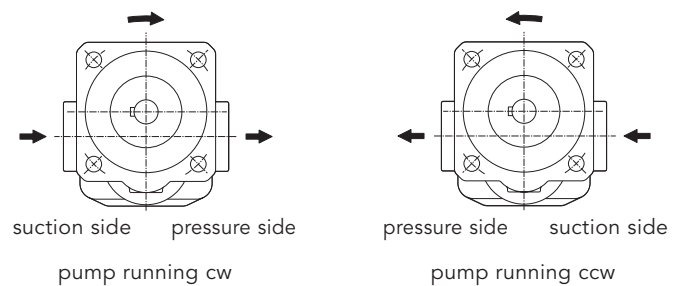

With pressure relief valve

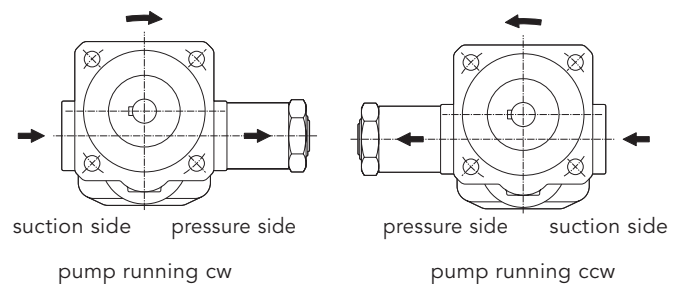

With universal device

Direction of rotation right and left

Direction of rotation consistent, see dimension sheets page 23 and 24.

Materials

Housing and cover	EN-GJL-250 (GG 25) EN-GJS-400-15 (GGG 40) on request
Gear	Steel 1.7139
Plain bearing bushes	DU (multi-layer friction-type bearings P 10, DP 4) Bearings free of nonferrous metal on request
Shaft end seals	NBR, FKM, PTFE, EPDM (other sealing materials on request. E.g. HNBR/CR)
O-ring	NBR, FKM, PTFE, EPDM (other sealing materials on request. E.g. HNBR/CR)

Characteristics

Nominal sizes 4...80 cm ³	$V_g =$	4/5/6/8/10/12/16/20/25/32/40/50/63/80
Fitting position		arbitrary (exception: see universal device)
Direction of rotation		right or left right and left
Fixing type		flange (DIN ISO 3019)
Pipe connection	KF 4...25 KF 32...80	Whitworth pipe thread, SAE flange SAE flange
Drive shaft end		ISO R 775 short-cylindrical
Operating pressure suction side		see chart page 8
Operating pressure pressure side	P_n	25 bar (higher pressures on request)
Speed	KF 4...80	200 ... 3 000 1/min
Viscosity (dependent on pressure and rotational speed)	mm ² /s	12 ... 20 000
Temperature of pumping media		see chart page 8
Ambient temperature	$V_u =$	-20 °C ... 60 °C (-4 °F ... 140 °F)

Shaft End Seals

	Sealing material	Pressure suction side* bar	Fluid temperature	
			°C	°F
Pump with single rotary shaft lip	NBR	-0.4...1	-10...90	-14...194
	FKM max. 750 Upm	-0.4...6	-10...150	-14...302
	max. 1000 Upm	-0.4...5		
	max. 1500 Upm	-0.4...4		
	max. 2000 Upm	-0.4...3		
	max. 3000 Upm	-0.4...2		
FKM (low temperature)	-0.4...0.5	-40...150	-40...302	
EPDM	-0.4...0.5	-10...120	-14...248	
PTFE	-0.4...2	-10...200	-14...392	
Pump with outboard bearing and single rotary shaft lip	NBR	-0.4...1	-10...90	-14...194
	FKM max. 750 Upm	-0.4...6	-10...150	-14...302
	max. 1000 Upm	-0.4...5		
	max. 1500 Upm	-0.4...4		
	max. 2000 Upm	-0.4...3		
	max. 3000 Upm	-0.4...2		
PTFE	-0.4...2	-10...200	-14...392	
Pump with double rotary shaft seal with connection borehole for liquid seal (quench)	NBR	-0.4...1	-10...90	-14...194
	FKM max. 750 Upm	-0.4...6	-10...150	-14...302
	max. 1000 Upm	-0.4...5		
	max. 1500 Upm	-0.4...4		
	max. 2000 Upm	-0.4...3		
	max. 3000 Upm	-0.4...2		
PTFE	-0.4...2	-10...200	-14...392	
Pump with double rotary shaft seal for vacuum operation with connection borehole for liquid seal (quench)	NBR	-0.9...0.2	-10...90	-14...194
	FKM	-0.9...0.2	-10...150	-14...302
	PTFE	-0.9...0.2	-10...200	-14...392
Pump with triple rotary shaft seal for vacuum and normal operation with connection borehole for fluid liquid seal (quench)	NBR	-0.9...1	-10...90	-14...194
	FKM max. 750 Upm	-0.9...6	-10...150	-14...302
	max. 1000 Upm	-0.9...5		
	max. 1500 Upm	-0.9...4		
	max. 2000 Upm	-0.9...3		
	max. 3000 Upm	-0.9...2		
Pump with mechanical seal	FKM	-0.4...10	-10...150	-14...302
	PTFE	-0.4...10	-10...200	-14...392
	EPDM	-0.4...10	-10...120	-14...248
Pump with mechanical seal and connection borehole for liquid seal	FKM	-0.4...10	-10...150	-14...302

* short term during start-up status: -0.6 bar

Speed: 200–3000 1/min

The indicated maximum values are dependent upon the remaining operating conditions.

In case of universal devices, pay attention to limitation of $P_{e \text{ min}}$.

Other sealing materials on request.

Variants

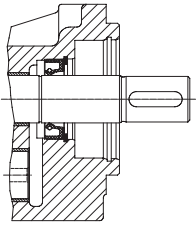

Pump with single rotary shaft lip

Fixing type: F/W

Sealing materials:

NBR = sealing type 1

FKM = sealing type 2

PTFE = sealing type 3

EPDM = sealing type 9

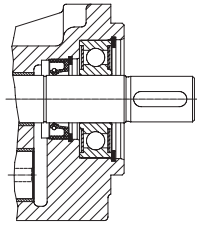

Pump with outboard bearing and single rotary shaft lip

Fixing type: G/X

Sealing materials:

NBR = sealing type 1

FKM = sealing type 2

PTFE = sealing type 3

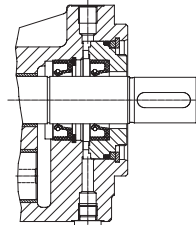

Pump with double rotary shaft seal with connection borehole for liquid seal (quench)

Fixing type: F/W

Sealing materials:

NBR = sealing type 19

FKM = sealing type 7

PTFE = sealing type 4

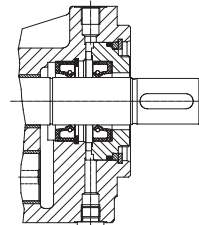

Pump with double rotary shaft seal for vacuum operation with connection borehole for liquid seal (quench)

Fixing type: F/W

Sealing materials:

NBR = sealing type 19

FKM = sealing type 7

PTFE = sealing type 4

Special number: 74

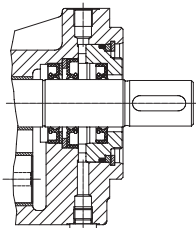

Pump with triple rotary shaft seal for vacuum and normal operation with connection borehole for fluid liquid seal

Fixing type: F/W

Sealing materials:

NBR = on request

FKM = on request

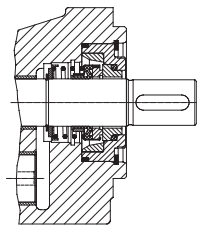

Pump with mechanical seal

Fixing type: F/W

Sealing materials:

FKM = sealing type 5

PTFE = sealing type 6

EPDM = sealing type 20

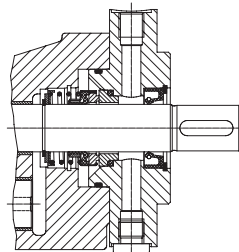

Pump with mechanical seal and connection borehole for liquid seal

Fixing type: F/W

Sealing materials:

FKM = sealing type 5

Special number: 198

KF 4...80 noise optimized

The noise optimized pumps in the KF series are designed for conveying media with higher proportions of air, predominantly for use as lubricating oil pumps in transmissions. Special measures prevent the otherwise normally increased noise present in auriferous transmission oil. The noise levels do not exceed or only barely exceed the measurements with non-auriferous oils. Also, there is no noise spectrum shift to higher, unpleasant frequencies. In applications without auriferous portions in the media, it is not recommended to use this version as it will not bring about noise reduction effects there.

The noise optimized version of the KF pump is marked with the special number **197** at the end of the rating plate.

pumps with the special number **197** are built as pumps in combination with an electric motor or as mounted pumps. The pump in combination with an electric motor (Fig. 1) does not have an outboard bearing, so it has to be driven via an elastic coupling. The mounted pump (Fig. 2) comes equipped with an outboard bearing to absorb the centrifugal forces such as those which arise when using a flying pinion. Pumps for electric motor drives and mounted pumps are sealed at the shaft end using a lip-type shaft seal.

Fig. 1

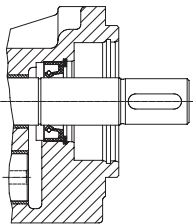
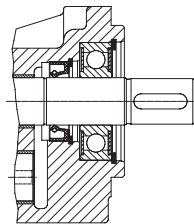

Fig. 2



Pump with single rotary shaft lip

Fixing type: F/W

Sealing materials:

NBR = sealing type 1

FKM = sealing type 2

Special number: 197

Pump with outboard bearing and single rotary shaft lip

Fixing type: G/X

Sealing materials:

NBR = sealing type 1

FKM = sealing type 2

Special number: 197

The noise optimized version is also available in a ductile cast iron version. We can supply these pumps in the ATEX version also.

Note

Dimensions conformable Standard

KF transfer gear pump

Type Key

Ordering example

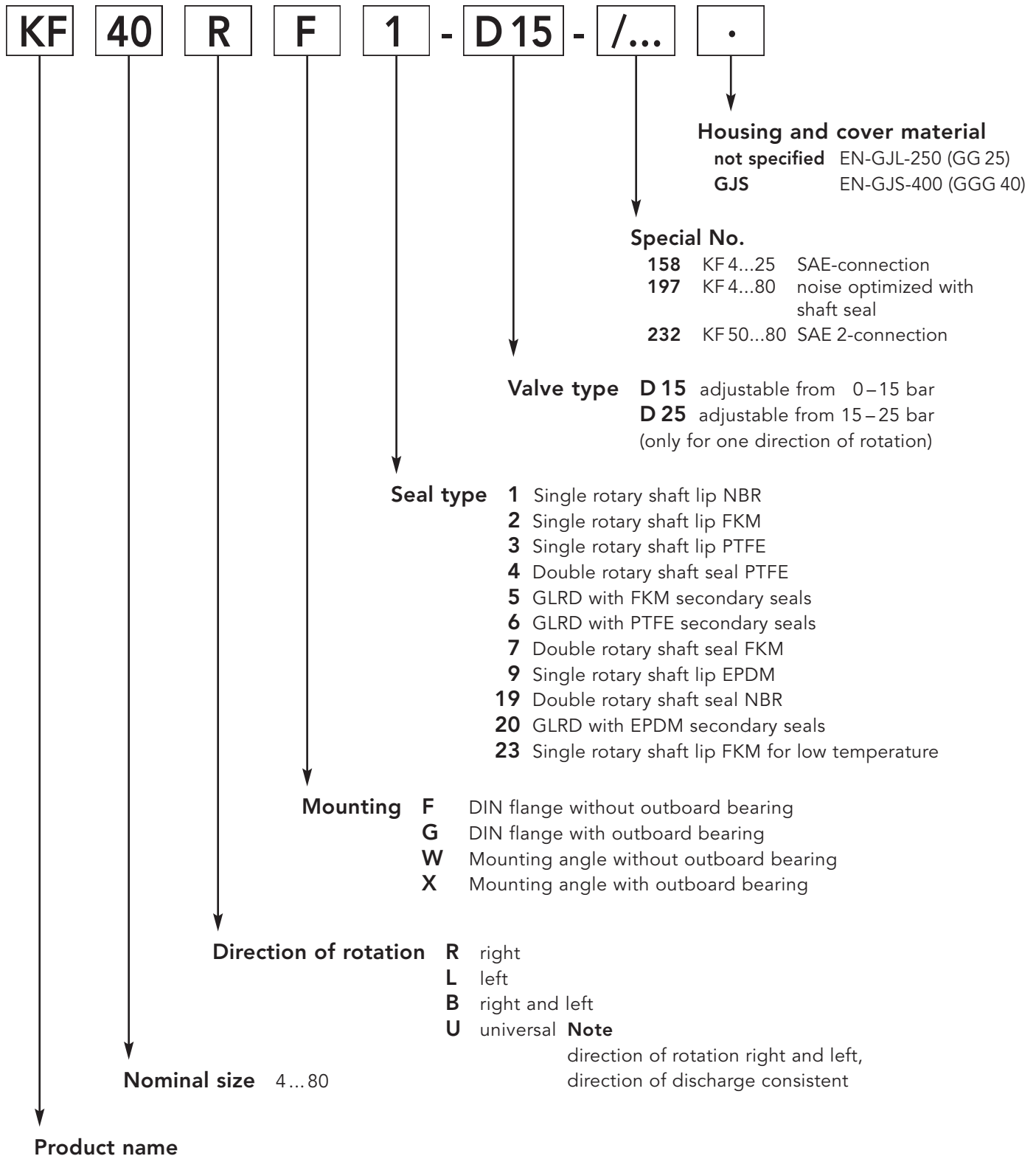

Technical Data

Nominal size	geometrical displacement V_g cm ³ /r	Operating pressure * p_b bar	Maximum pressure (pressure peaks) p_{max} bar	Speed range		Permissible load ** (n=1500 1/min) F_{radial} N
				n_{min} 1/min	n_{max} 1/min	
4	4.03	25	40	200	3000	700
5	5.05					
6	6.38					
8	8.05					
10	10.11					
12	12.58					
16	16.09					
20	20.1					
25	25.1					
32	32.12					
40	40.21					
50	50.2					
63	63.18					
80	80.5					
						1500

Remark

* Operating pressure p_b = perm. sustained pressure

** Permissible load only for version with outboard bearing. F_{radial} at centre of shaft end.

For certain operating conditions, the minimum or maximum characteristics should not be used.

For example, the max. operating pressure is not permissible in combination with low speed and low viscosity.

In such limit ranges, please consult us.

Power Consumption

Speed n = 950 1/min

Discharge Q in l/min	Pressure p _b in bar								Nominal size	Pressure p _b in bar								Power consumption P in KW
	2	4	6	8	10	15	20	25		2	4	6	8	10	15	20	25	
	3.7	3.6	3.6	3.5	3.4	3.3	3.1	2.9		4	0.04	0.05	0.07	0.08	0.09	0.13	0.16	
4.6	4.5	4.5	4.4	4.3	4.1	3.8	3.6	5	0.04	0.06	0.08	0.10	0.11	0.16	0.20	0.25		
5.8	5.7	5.6	5.5	5.4	5.1	4.9	4.6	6	0.05	0.07	0.09	0.12	0.14	0.19	0.25	0.30		
7.3	7.2	7.1	7.0	6.8	6.5	6.2	5.8	8	0.06	0.09	0.11	0.14	0.17	0.24	0.31	0.38		
9.2	9.0	8.9	8.7	8.6	8.2	7.7	7.3	10	0.07	0.10	0.14	0.17	0.21	0.29	0.38	0.47		
11.4	11.3	11.1	10.9	10.7	10.2	9.6	9.1	12	0.08	0.12	0.16	0.21	0.25	0.36	0.47	0.58		
14.6	14.4	14.2	13.9	13.7	13.1	12.4	11.7	16	0.09	0.15	0.20	0.26	0.31	0.45	0.60	0.74		
18.2	18.0	17.7	17.4	17.1	16.3	15.5	14.7	20	0.10	0.18	0.25	0.32	0.39	0.56	0.74	0.92		
22.8	22.4	22.1	21.7	21.3	20.4	19.4	18.3	25	0.12	0.21	0.30	0.39	0.48	0.70	0.92	1.14		
29	29	28	28	27	26	25	23	32	0.2	0.3	0.4	0.5	0.6	0.9	1.2	1.5		
37	36	36	35	34	33	31	29	40	0.2	0.4	0.5	0.6	0.8	1.1	1.5	1.8		
46	45	44	43	43	41	38	36	50	0.3	0.5	0.6	0.8	1.0	1.4	1.9	2.3		
58	57	56	55	54	51	48	45	63	0.4	0.6	0.8	1.0	1.2	1.8	2.4	2.9		
73	72	71	69	68	65	61	58	80	0.4	0.7	1.0	1.3	1.6	2.3	3.0	3.7		

Speed n = 1450 1/min

Discharge Q in l/min	Pressure p _b in bar								Nominal size	Pressure p _b in bar								Power consumption P in KW
	2	4	6	8	10	15	20	25		2	4	6	8	10	15	20	25	
	5.7	5.6	5.6	5.5	5.4	5.3	5.1	4.9		4	0.06	0.08	0.10	0.12	0.15	0.20	0.25	
7.1	7.1	7.0	6.9	6.8	6.6	6.4	6.1	5	0.07	0.10	0.12	0.15	0.18	0.24	0.31	0.38		
9.0	8.9	8.8	8.7	8.6	8.3	8.0	7.8	6	0.08	0.11	0.15	0.18	0.21	0.30	0.38	0.47		
11.3	11.2	11.1	11.0	10.9	10.5	10.2	9.8	8	0.09	0.14	0.18	0.22	0.26	0.37	0.47	0.58		
14.2	14.1	14.0	13.8	13.6	13.2	12.8	12.4	10	0.11	0.16	0.21	0.27	0.32	0.45	0.58	0.72		
17.7	17.6	17.4	17.2	17.0	16.5	15.9	15.4	12	0.12	0.19	0.26	0.32	0.39	0.55	0.72	0.89		
22.6	22.4	22.2	22.0	21.7	21.1	20.5	19.8	16	0.16	0.26	0.37	0.47	0.57	0.82	1.08	1.33		
28.3	28.0	27.7	27.4	27.1	26.4	25.6	24.7	20	0.17	0.28	0.39	0.49	0.60	0.87	1.14	1.41		
35.3	35.0	34.6	34.3	33.9	32.9	31.9	30.9	25	0.20	0.34	0.47	0.61	0.74	1.08	1.41	1.75		
45	45	44	44	43	42	40	39	32	0.3	0.5	0.7	0.8	1.0	1.4	1.9	2.3		
56	56	55	55	54	52	50	49	40	0.4	0.6	0.9	1.1	1.3	1.8	2.3	2.9		
70	70	69	68	67	65	63	61	50	0.5	0.8	1.1	1.3	1.6	2.3	2.9	3.6		
89	88	87	86	85	82	79	77	63	0.7	1.0	1.3	1.7	2.0	2.9	3.7	4.5		
113	112	111	109	108	105	101	98	80	0.8	1.2	1.7	2.1	2.5	3.6	4.7	5.8		

The ratings refer to a mineral oil with a viscosity of 34 mm²/s.

Margin of error for the flow Q + 2.5 % ... - 5 % of the tabular value. For viscosity < 30 mm²/s, take a reduction of the rated flow Q into account.

The output of the drive motor should be selected 20 % higher than tabular value P.

For viscosity > 100 mm²/s, an increase in the required power is necessary, in this case proceed as per description on page 14/15.

Discharge Flow / Input Power

Calculation

$$P_{1Pu} = P_{tab} \cdot \frac{n}{1450} + f_v \cdot Q$$

P_{1Pu} = pump power consumption (kW)

P_{tab} = power consumption per table (kW) at 1450 1/min

n = speed (1/min)
dependent on viscosity!
(see speed recommendation)

f_v = viscosity factor $\left[\frac{\text{kW}}{\text{l/min}} \right]$
see diagram page 14

Q = discharge flow (l/min) with $Q = \frac{V_g \cdot n}{1000}$

V_g = geometrical
displacement (cm³/r)

Example: Pump type KF 80

Viscosity $v = 3000 \text{ mm}^2/\text{s}$

Operating pressure $p = 15 \text{ bar}$

at $P_{tab} = 3.6 \text{ kW}$

$n = 500 \text{ 1/min}$

$f_v = 0.017 \frac{\text{kW}}{\text{l/min}}$

$$Q = \frac{80.5 \cdot 500}{1000} = 40 \text{ l/min}$$

becomes

$$P_{1Pu} = \left(3.6 \cdot \frac{500}{1450} + 0.017 \cdot 40 \right) \text{ kW}$$

$P_{1Pu} = 1.92 \text{ kW}$

Motor

power output: $P_{2Mot} = 1.2 \cdot P_{1Pu} = 2.3 \text{ kW}$

Select helical

geared motor with

$P = 3.0 \text{ kW}$

$n = 500 \text{ 1/min}$

Conversion factors

$$1 \text{ bar} \triangleq 14.5 \frac{\text{lb}}{\text{in}^2} = 14.5 \text{ psi}$$

$$1 \frac{\text{l}}{\text{min}} \triangleq 0.220 \frac{\text{gal}}{\text{min}} = [\text{U.K.}]$$

$$1 \frac{\text{l}}{\text{min}} \triangleq 0.264 \frac{\text{gal}}{\text{min}} = [\text{US}]$$

Speed recommendation

Kinematic viscosity $v \text{ mm}^2/\text{s}$

<	300	300	500	1000	2000	3000	6000	10000	20000	30000
≥	1500	1250	1000	750	600	500	400	300	200	100

Speed $n_{max} \text{ 1/min}$

Input Power



Diagramm: $n, f_v = f(v)$

Note:

To determine the power consumption, always take the max. operating viscosity at starting state into consideration. The power of the drive motor should be selected 20% higher than the value determined.

Flange-Mounting Version with Pipe Thread

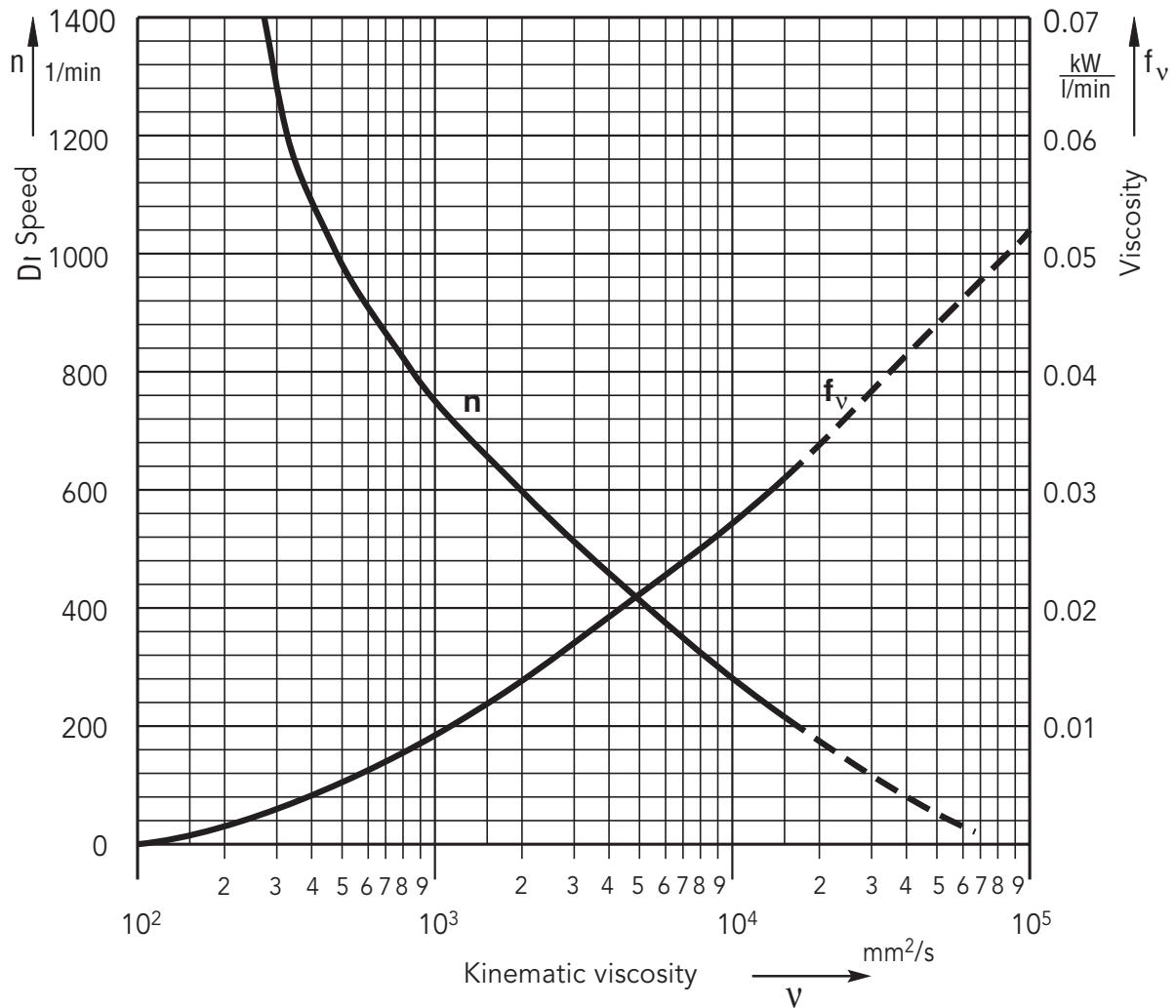
KF 4...25

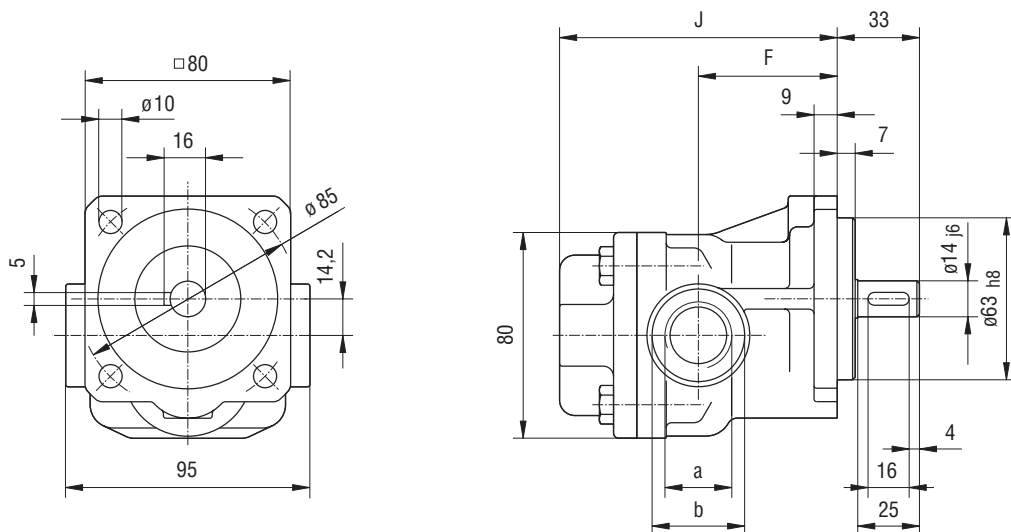

KF 4...25 with pressure relief valve

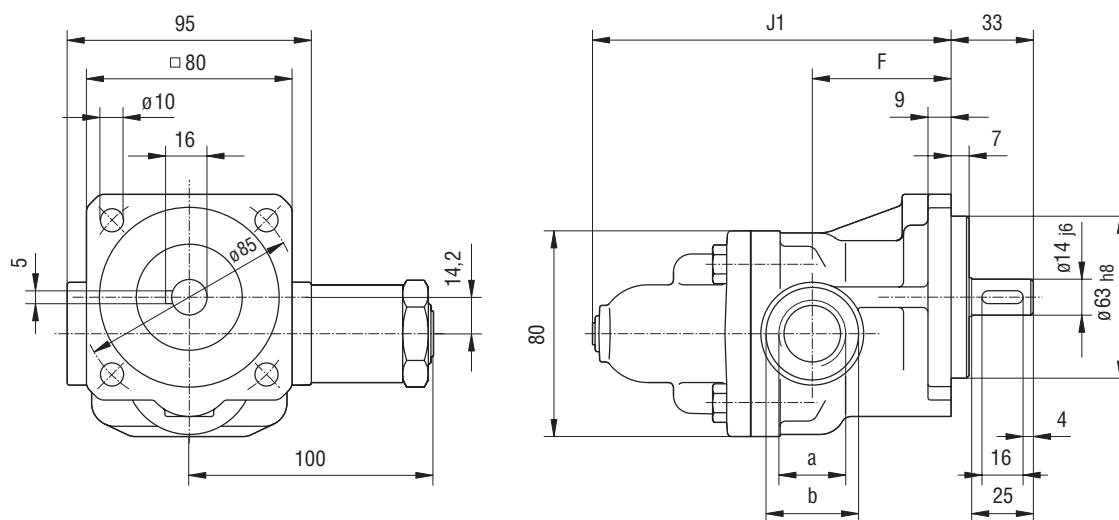

Nominal size	Suction and pressure connection		F	J	J ₁	Weight in kg	
	a	b				without valve	with valve
4...12	G 3/4 17 deep	Ø 36	54	109	140	2.9	3.7
16...25	G 1 19 deep	Ø 42	63	131	161	3.5	4.3

Flange-Mounting Version with SAE 3/4 and 1-Connection (Special No. 158)

KF 4... 25

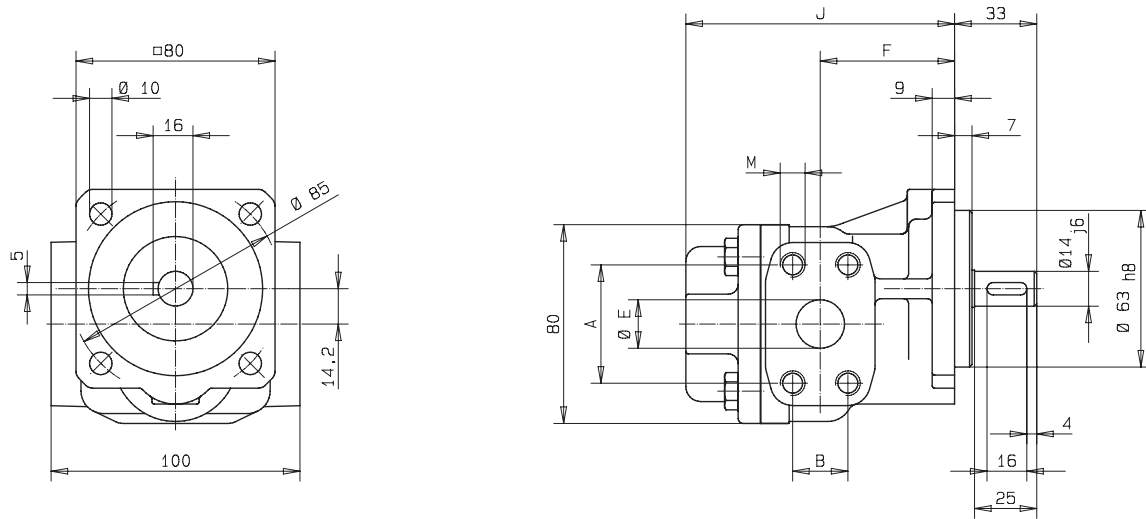

KF 4... 25 with pressure relief valve

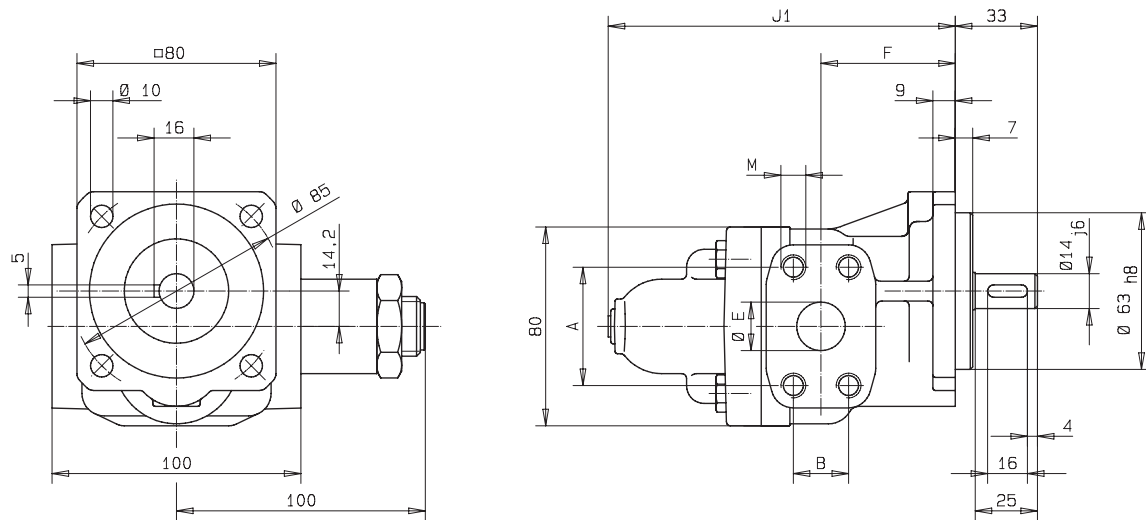

Nominal size	Suction and pressure connection								Weight in kg	
		A	B	E	M	F	J	J ₁	without valve	with valve
4...12	SAE 3/4	47.6	22.2	19.5	M10 15 deep	54	109	140	4.2	5.0
16...25	SAE 1	52.4	26.2	25	M10 17 deep	63	131	162	4.8	5.6

Flange-Mounting with SAE 1 1/2-Connection

KF 32...80

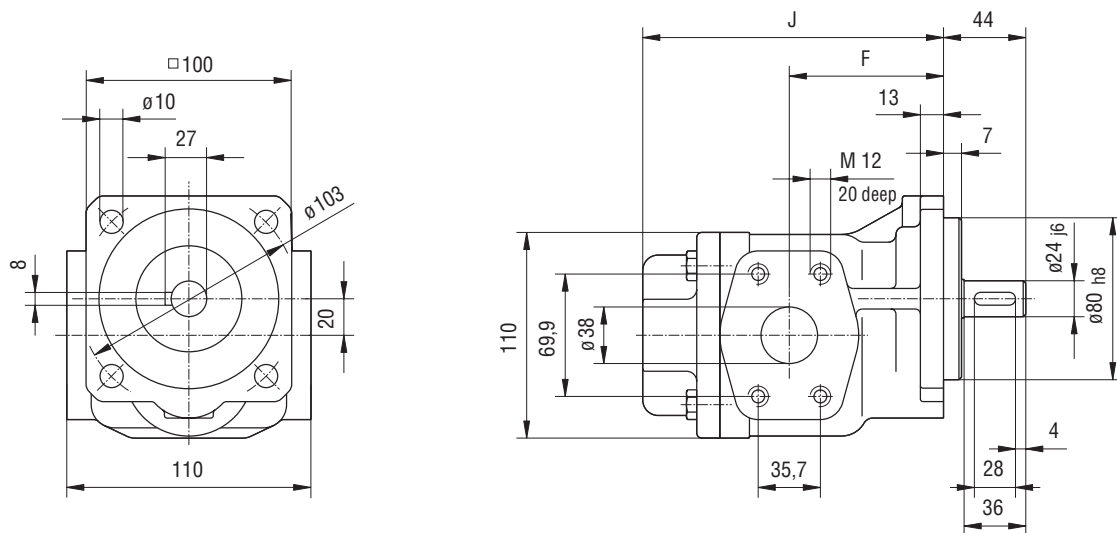

KF 32...80 with pressure relief valve

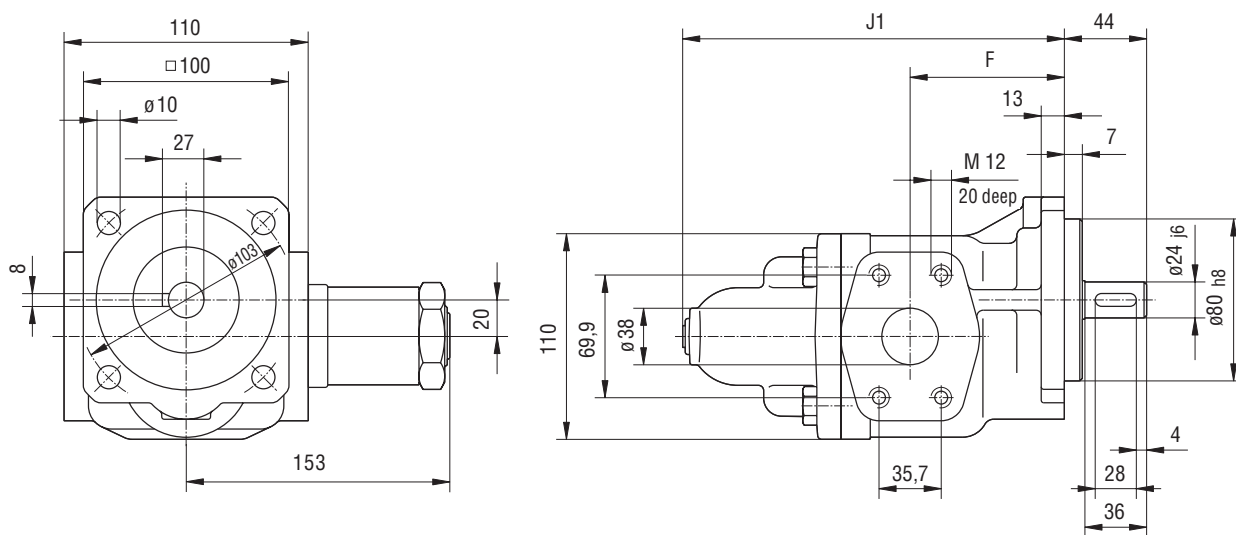

Nominal size		F	J	J ₁	Weight in kg	
					without valve	with valve
32...50	SAE 1 1/2	84	173	212	7.7	9.5
63 / 80	SAE 1 1/2	100	208	247	9.4	11.2

Flange-Mounting Version with SAE 2-Connection (Special No. 232)

KF 50... 80

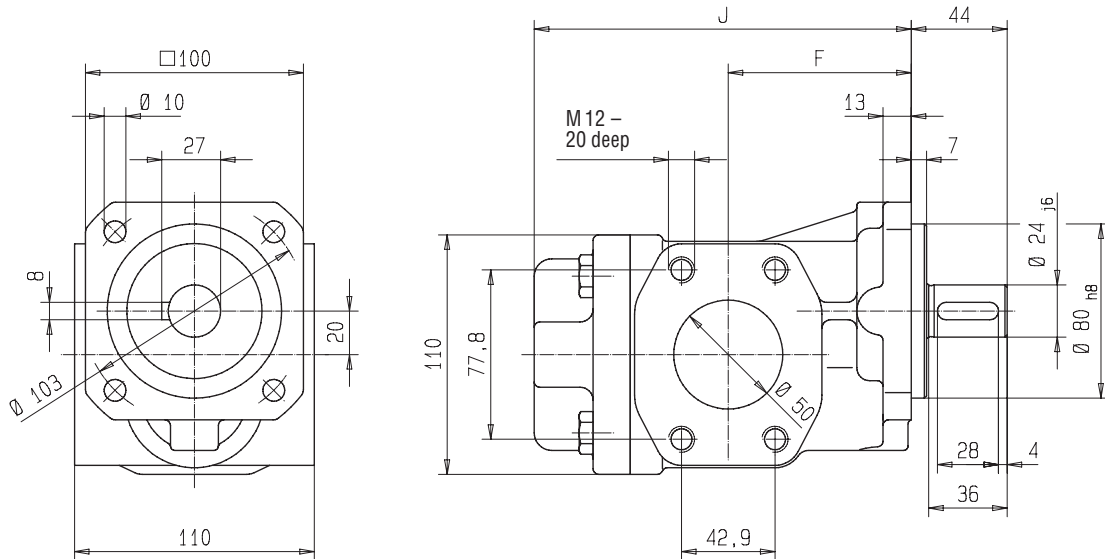

KF 50... 80 with pressure relief valve

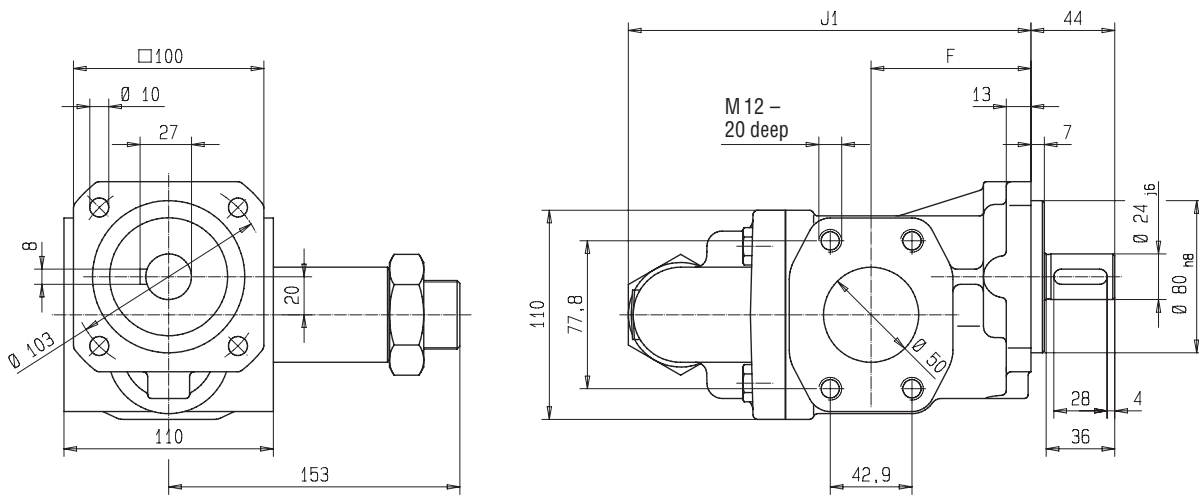

Nominal size		F	J	J ₁	Weight in kg	
					without valve	with valve
50	SAE 2	84	121	212	7.7	9.5
63 / 80	SAE 2	100	206	217	9.4	11.2

Pump with Mounting Angle, Pipe Thread

KF 4...25

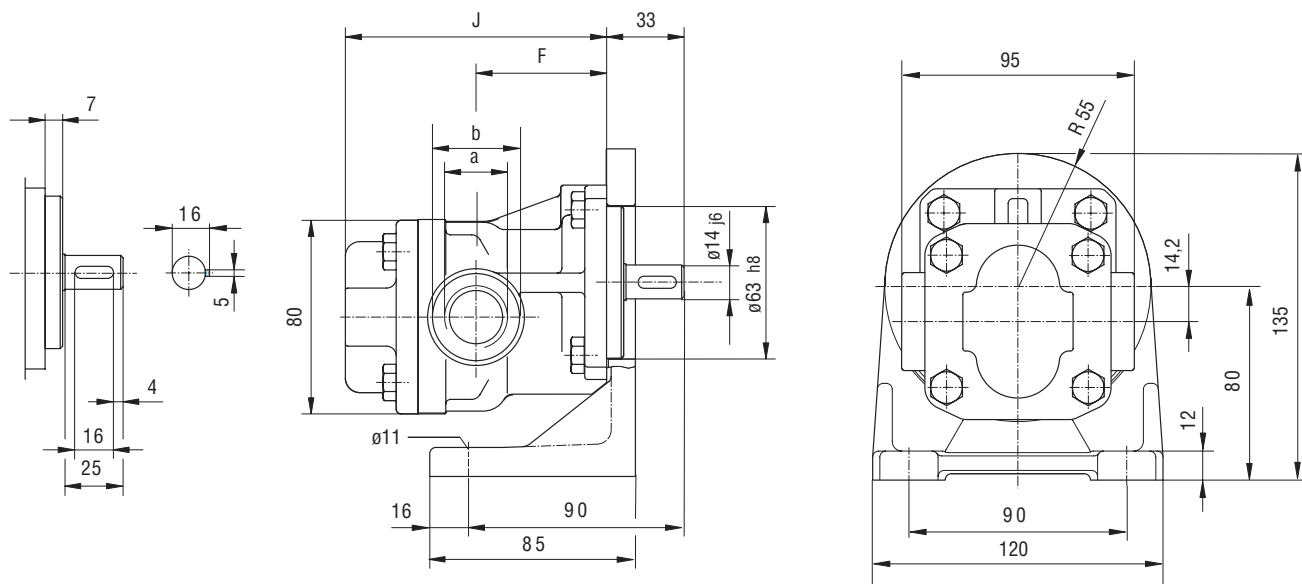

KF 4...25 with pressure relief valve

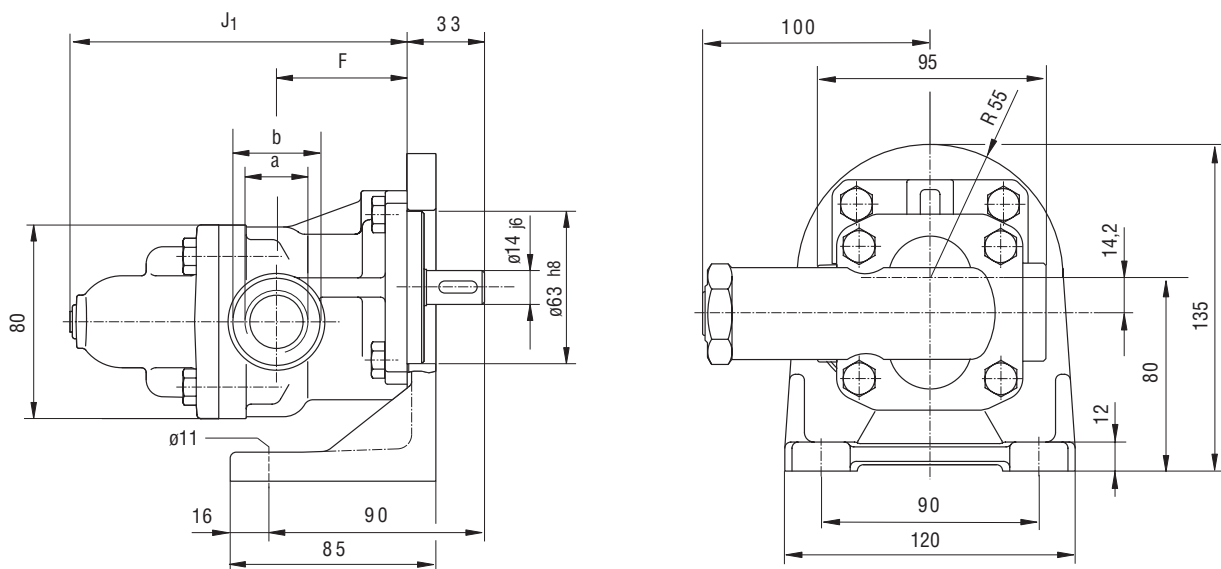

Nominal size	Suction and pressure connection		F	J	J ₁	Weight in kg	
	a	b				without valve	with valve
4...12	G 3/4 17 deep	Ø 36	54	109	140	4.2	5.0
16...25	G 1 19 deep	Ø 42	63	131	161	4.8	5.6

Pump with Mounting Angle, SAE 3/4 and 1-Connection (Special No. 158)

KF 4... 25

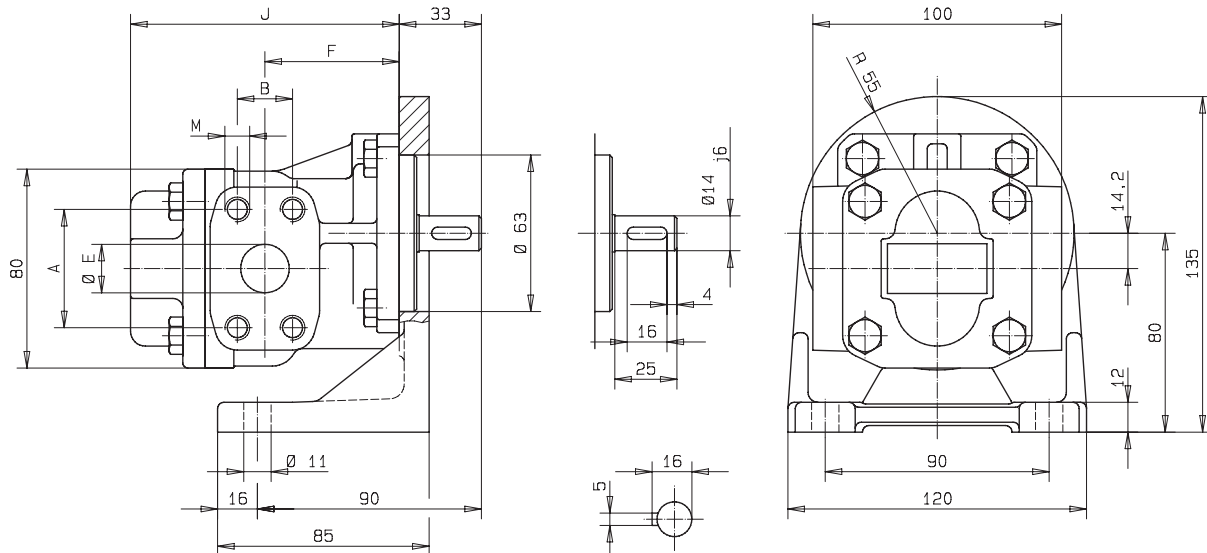

KF 4... 25 with pressure relief valve

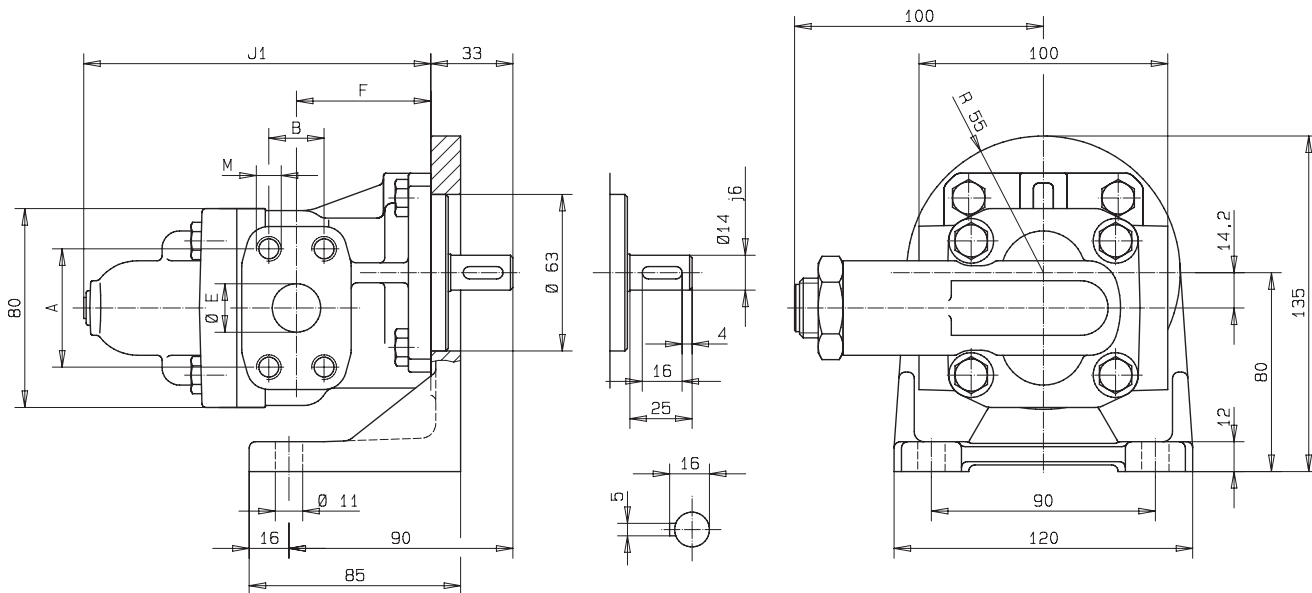

Nominal size	Suction and pressure connection								Weight in kg	
		A	B	E	M	F	J	J ₁	without valve	with valve
4...12	SAE 3/4	47.6	22.2	19.5	M10 15 deep	54	109	140	4.2	5.0
16...25	SAE 1	52.4	26.2	25	M10 17 deep	63	131	162	4.8	5.6

Pump with Mounting Angle, SAE 1 1/2-Connection

KF 32... 80

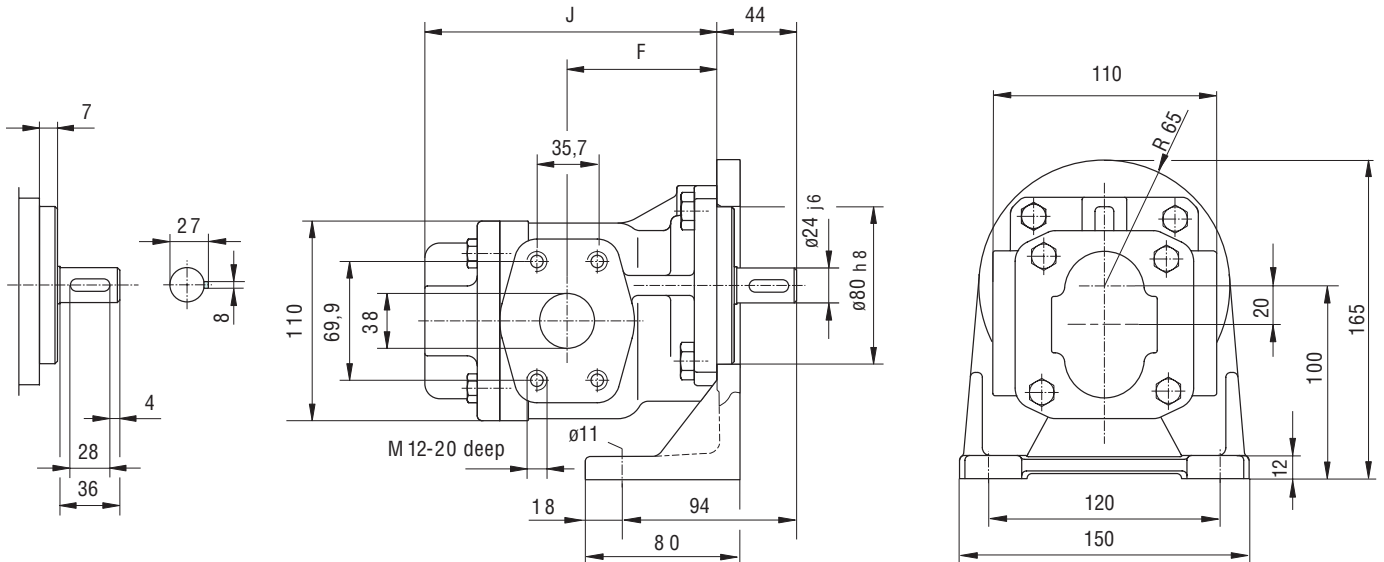

KF 32... 80 with pressure relief valve

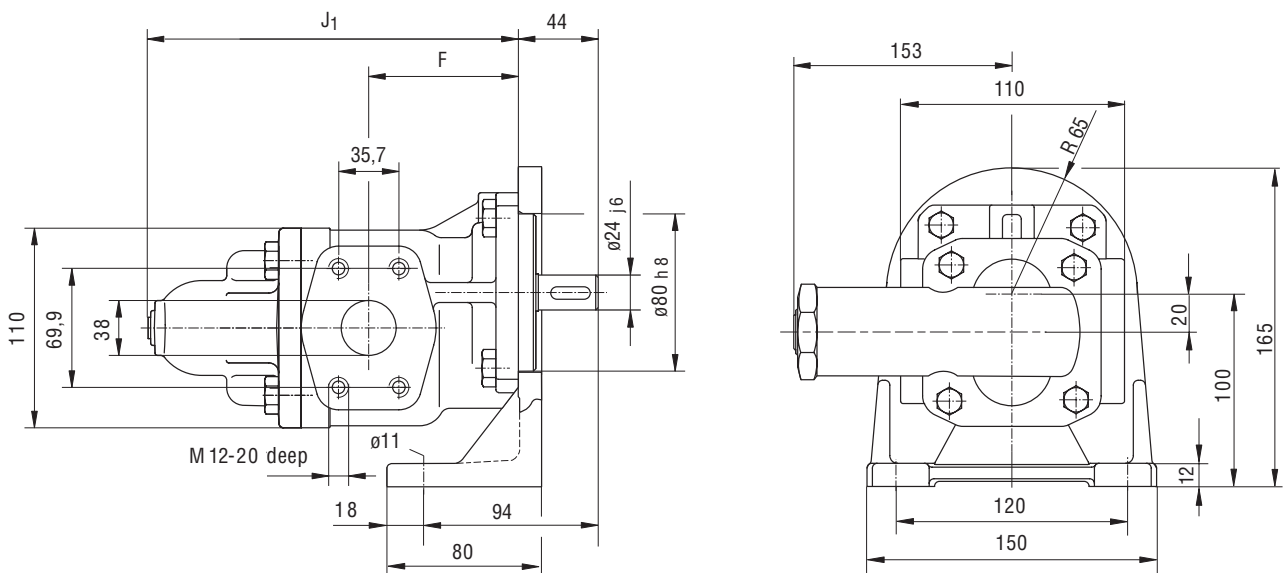

Nominal size		F	J	J ₁	Weight in kg	
					without valve	with valve
32...50	SAE 1 1/2	84	173	212	9.5	11.3
63 / 80	SAE 1 1/2	100	208	247	11.2	13,0

Pump with Mounting Angle, SAE 2-Connection (Special No. 232)

KF 50... 80

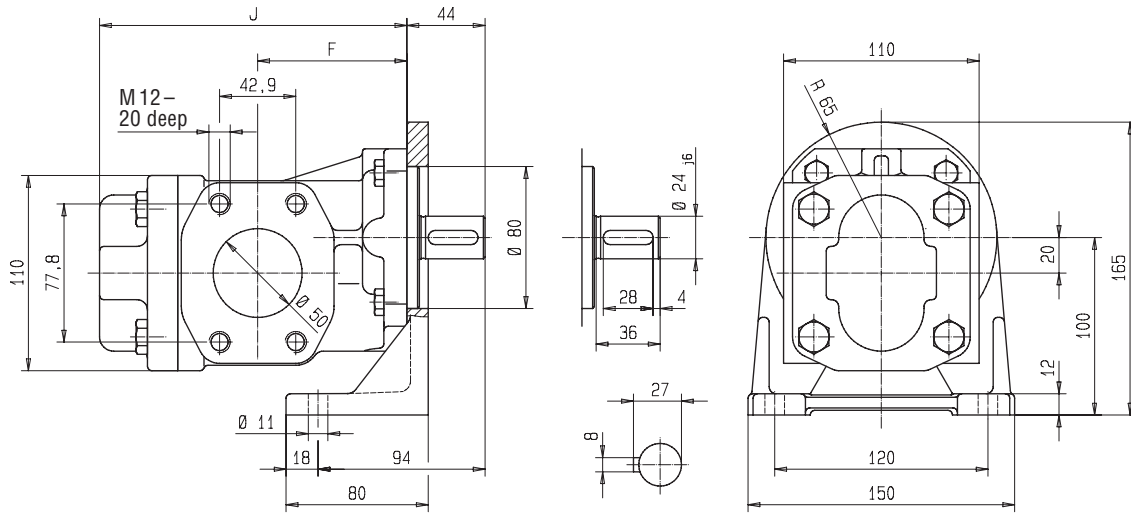

KF 50... 80 with pressure relief valve

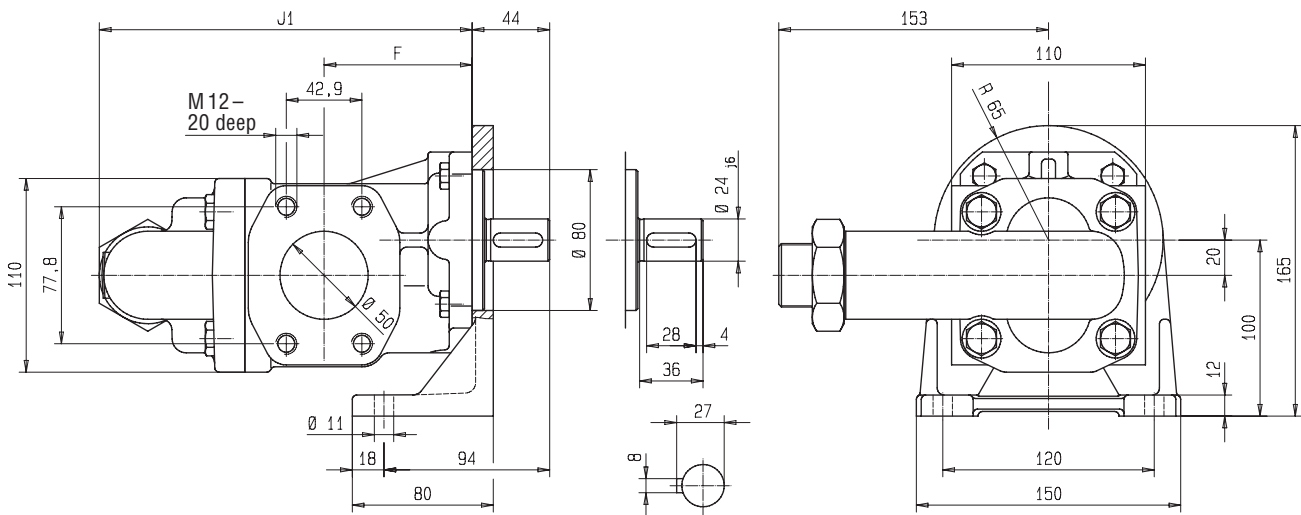

Nominal size		F	J	J ₁	Weight in kg	
					without valve	with valve
50	SAE 2	84	121	212	9.5	11.3
63 / 80	SAE 2	106	206	217	11.2	13.0

Accessory Couplings

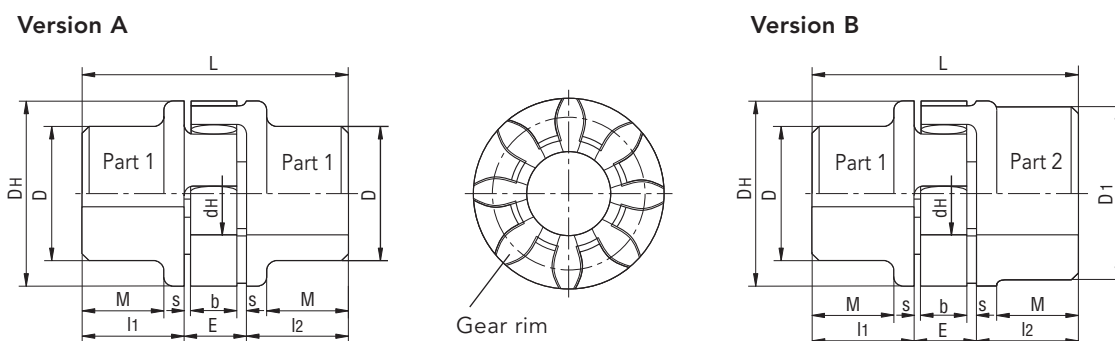

	Ordering code	Coupling size	Hub material (AL)		Pre-bore		Finished bore		Dimensions											
			Weight kg	Moment of inertia kgm ²	part 1	part 2	min.		max.		l1/l2	E	s	b	L	M	DH	D	D ₁	dh
							part 1	part 2	part 1	part 2										
Version A	RA 19-Z 25/...-Z 25/..	19	0.117	0.00003	4	-	6	-	19	-	25	16	2	12	66	20	40	32	-	18
	RA 24-Z 30/...-Z 30/..	24	0.24	0.00008	6	-	8	-	24	-	30	18	2	14	78	24	55	40	-	27
	RA 28-Z 35/...-Z 35/..	28	0.39	0.0002	8	-	10	-	28	-	35	20	2.5	15	90	28	65	48	-	30
	RA 38-Z 45/...-Z 45/..	38	0.82	0.0007	10	-	12	-	38	-	45	24	3	18	114	37	80	66	-	38
Version B	RA 19/24-Z 25/...-Z 25/..	19/24	0.129	0.00004	4	17	6	19	19	24	25	16	2	12	66	20	40	32	40	18
	RA 24/28-Z 30/...-Z 30/..	24/28	0.26	0.0001	6	22	8	24	24	28	30	18	2	14	78	24	55	40	48	27
	RA 28/38-Z 35/...-Z 35/..	28/38	0.46	0.0003	8	26	10	28	28	38	35	20	2.5	15	90	28	65	48	65	30
	RA 38/45-Z 45/...-Z 45/..	38/45	0.89	0.0008	10	36	12	38	38	45	45	24	3	18	114	37	80	66	76	38

Type Code KF Coupling

Ordering code

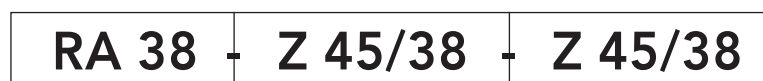

Coupling size

pump side
cylindrical

motor side
cylindrical

coupling hub length and hub bore

Operating temperature:
-20 °C to +80 °C (-4 °F to 176 °F)
(short duration temperature peaks up to 120 °C / 248 °F are permissible).

Weights and mass moments of inertia refer to max. finish machined bore without slot.
Finish-machined bores to ISO Fit H7,
parallel key slots in accordance with DIN 6886 Sh.1.

Bell Housing

KF 4... 25 Aluminum bell housing

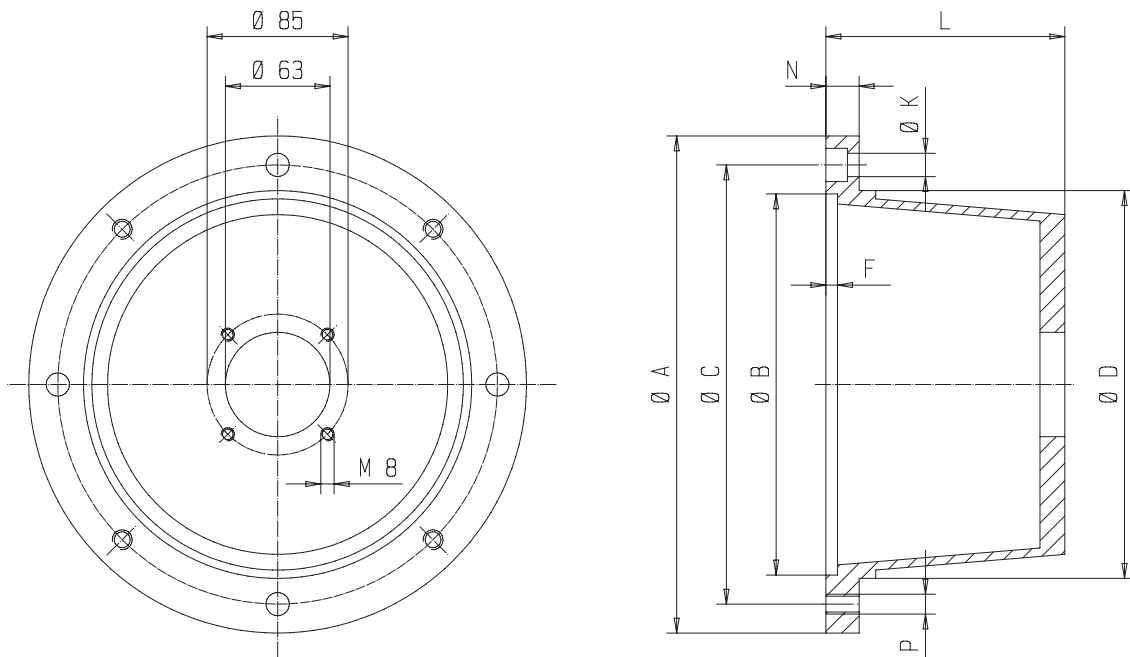

Size	Bell housing	Coupling	Mass									Weight kg
			A	B	C	D	F	K	L	N	P	
71 S	PT160-A-063-80	RA19-Z25/14-Z25/14	160	110	130	110	7	7	80	9	M8	1.01
71												
80 S	PT200-A-063-100	RA19-Z25/14-Z25/19	200	130	165	145	7	7	100	11	M10	1.06
80												
90 S	PT200-A-063-100	RA19/24-Z25/14-Z25/24	200	130	165	145	7	7	100	11	M10	1.06
90 L												
100 LS	PT250-A-063-120	RA24/28-Z30/14-Z30/28	250	180	215	190	7	7	120	14	M12	1.75
100 L												
112 M												

Bell Housing

KF 32...80 Aluminum bell housing

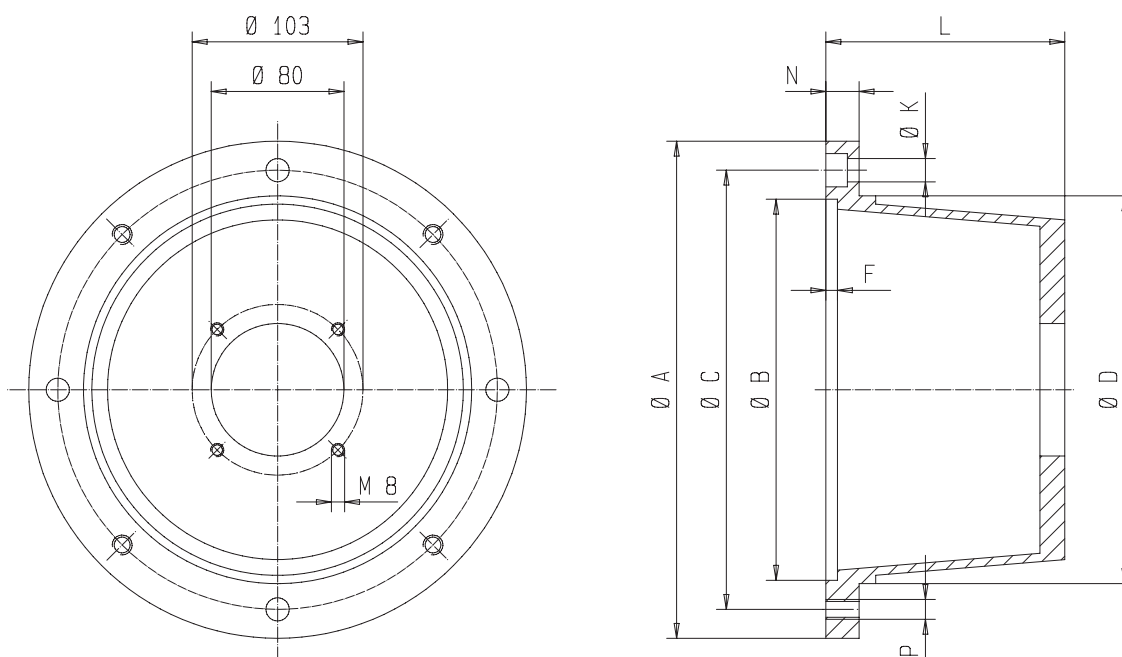

Size	Bell housing	Coupling	Mass									Weight kg
			A	B	C	D	F	K	L	N	P	
80 S	PT200-A-080-100	RA19/24-Z25/24-Z25/19	200	130	165	145	7	11	100	11	M10	1.41
80												
90 S	PT200-A-080-110	RA24-Z30/24-Z30/24	200	130	165	145	7	11	110	11	M10	1.19
90 L												
100 LS	PT250-A-080-124	RA24/28-Z30/24-Z30/28	250	180	215	190	7	14	124	14	M12	1.42
100 L												
112 M												
132 S	PT300-A-080-144	RA28/38-Z35/24-Z35/38	300	230	265	234	7	14	144	14	M12	2.10
132 M												
160 M	PT350-A-080-188	RA38/45-Z45/24-Z45/42	350	250	300	260	7	18	188	18	M16	3.05
160 L												

Motor-Pump Assemblies with Pipe Thread

KF 4... 25

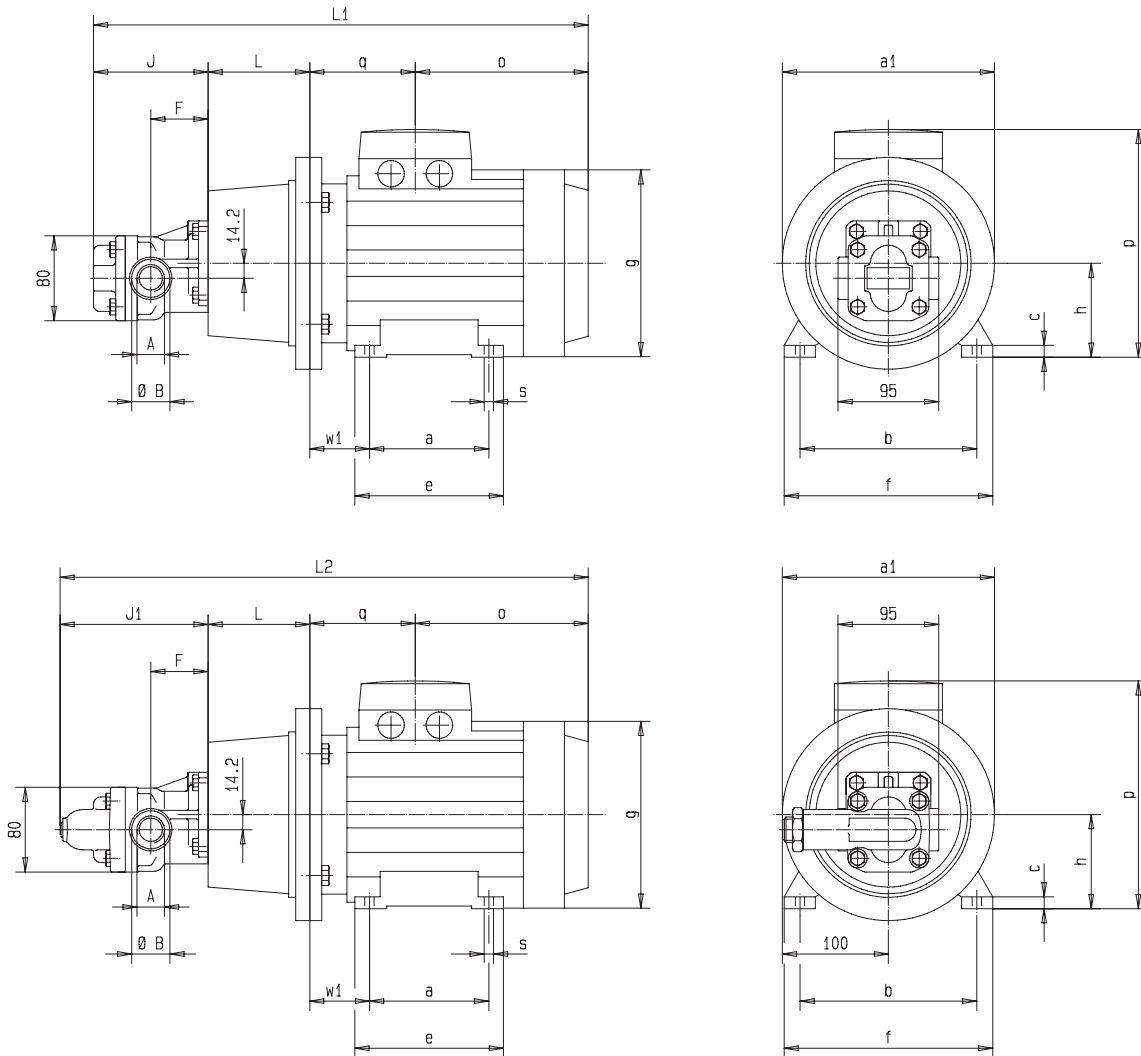

with pressure relief valve

KF 4... 25 Pump sizes

Nominal size	Suction and pressure connection		F	J	J ₁
	A	B			
4...12	G 3/4 17 deep	Ø 36	54	109	140
16...25	G 1 19 deep	Ø 42	63	131	162

Motor-Pump Assemblies with Pipe Thread

KF 4... 25

Frame size	Power Motor 6 pole		Power Motor 4 pole		Bell housing	Coupling	Total weight * kg	
	kW	1/min	kW	1/min			Nominal size 4...12 16...25	
71 S	0.18	920	0.25	1400	PT160-A-063-80	RA19-Z25/14-Z25/14	10	10.5
71	0.25	920	0.37	1410			11	11.5
80 S	0.37	920	0.55	1420	PT200-A-063-100	RA19-Z25/14-Z25/19	13.5	14
80	0.55	930	0.75	1420			14.5	15
90 S	0.75	930	1.1	1410	PT200-A-063-100	RA19/24-Z25/14-Z25/24	17.5	18
90 L	1.1	930	1.5	1420			20.5	21
100 LS	–	–	2.2	1430	PT250-A-063-120	RA24/28-Z30/14-Z30/28	26.5	27
100 L	1.5	950	3	1430			29.5	30
112 M	2.2	940	4	1435			32.5	33

* with pressure relief valve add, weight 0.8 kg

KF 4... 25 Dimensions

Frame size	Dimensions																	
	4...12		16...25		4...12		16...25		4 ... 25									
	L ₁ *	L ₁ *	L ₂ *	L ₂ *	L	a ₁	a	b	c*	e*	f*	g*	h	o*	p*	q*	ø s*	w ₁
71 S	397	419	428	450	80	160	90	112	9	112	136	130	71	127	176	81	7	45
71	397	419	428	450	80	160	90	112	9	112	136	130	71	127	176	81	7	45
80 S	434	456	465	487	100	200	100	125	10	125	154	150	80	138	190	87	10	50
80	434	456	465	487	100	200	100	125	10	125	154	150	80	138	190	87	10	50
90 S	466	488	472	494	100	200	100	140	10	125	170	177	90	134	217	99	10	56
90 L	466	488	497	519	100	200	125	140	10	150	170	177	90	159	217	99	10	56
100 LS	518	540	549	571	120	250	140	160	12	172	197	197	100	187	237	102	12	63
100 L	518	540	549	571	120	250	140	160	12	172	197	197	100	187	237	102	12	63
112 M	530	552	561	583	120	250	140	190	12	168	222	221	112	161	258	140	12	70

Note

* Dimensions dependent on motor typ
(drawing: manufacture ABB).

All pump and motor sizes can be combined.

Other manufactures motors can be supplied on request.
Motor frame sizes are based on DIN 42673/677.

Motor-Pump Assemblies with SAE 3/4 bzw. 1-Connection (Special No. 158)

KF 4... 25

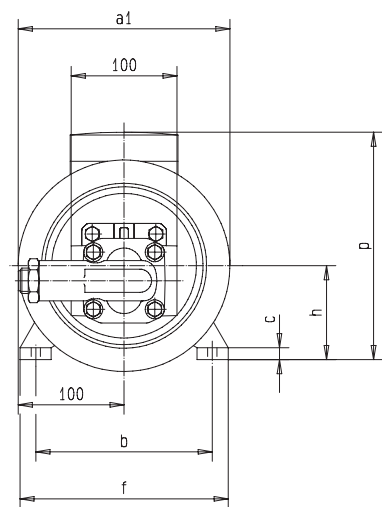
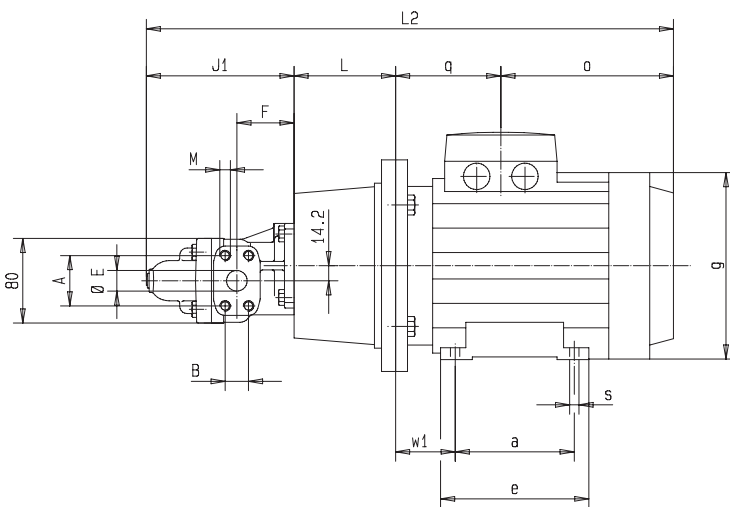
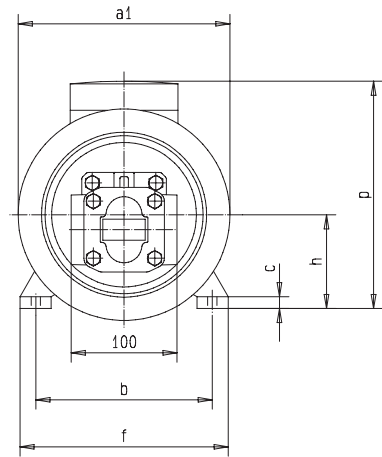
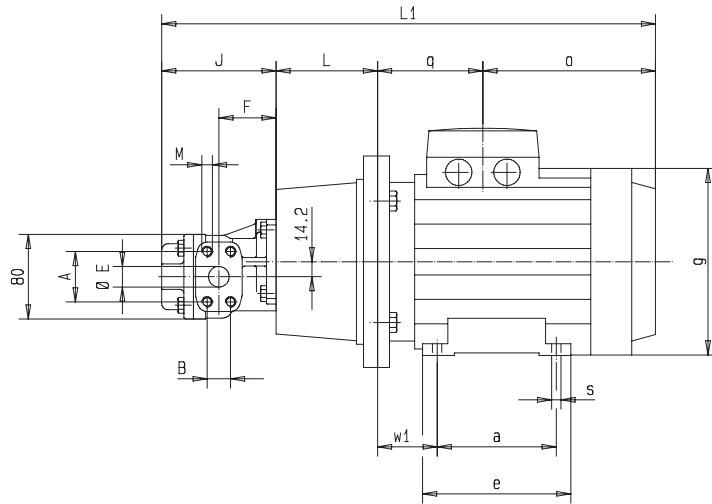

with pressure relief valve

KF 4... 25 Pump sizes

Nominal size	Suction and pressure connection								Weight in kg	
		A	B	E	M	F	J	J ₁	without valve	with valve
4...12	SAE 3/4	47.6	22.2	19.5	M10 15 deep	54	109	140	4.2	5.0
16...25	SAE 1	52.4	26.2	25	M10 17 deep	63	131	162	4.8	5.6

Motor-Pump Assemblies with SAE 3/4 bzw. 1-Connection (Special No. 158)

KF 4... 25

Frame size	Power Speed Motor 6 pole		Power Speed Motor 4 pole		Bell housing	Coupling	Total weight * kg	
	kW	1/min	kW	1/min			Nominal size 4...12 16...25	
71 S	0.18	920	0.25	1400	PT160-A-063-80	RA19-Z25/14-Z25/14	10	10.5
71	0.25	920	0.37	1410			11	11.5
80 S	0.37	920	0.55	1420	PT200-A-063-100	RA19-Z25/14-Z25/19	13.5	14
80	0.55	930	0.75	1420			14.5	15
90 S	0.75	930	1.1	1410	PT200-A-063-100	RA19/24-Z25/14-Z25/24	17.5	18
90 L	1.1	930	1.5	1420			20.5	21
100 LS	–	–	2.2	1430	PT250-A-063-120	RA24/28-Z30/14-Z30/28	26.5	27
100 L	1.5	950	3	1430			29.5	30
112 M	2.2	940	4	1435			32.5	33

* with pressure relief valve add, weight 0.8 kg

KF 4... 25 Dimensions

Bau- größe	Dimensions																	
	4...12 16...25		4...12 16...25		4 ... 25													
	L ₁ *	L ₁ *	L ₂ *	L ₂ *	L	a ₁	a	b	c*	e*	f*	g*	h	o*	p*	q*	ø s*	w ₁
71 S	397	419	428	450	80	160	90	112	9	112	136	130	71	127	176	81	7	45
71	397	419	428	450	80	160	90	112	9	112	136	130	71	127	176	81	7	45
80 S	434	456	465	487	100	200	100	125	10	125	154	150	80	138	190	87	10	50
80	434	456	465	487	100	200	100	125	10	125	154	150	80	138	190	87	10	50
90 S	466	488	472	494	100	200	100	140	10	125	170	177	90	134	217	99	10	56
90 L	466	488	497	519	100	200	125	140	10	150	170	177	90	159	217	99	10	56
100 LS	518	540	549	571	120	250	140	160	12	172	197	197	100	187	237	102	12	63
100 L	518	540	549	571	120	250	140	160	12	172	197	197	100	187	237	102	12	63
112 M	530	552	561	583	120	250	140	190	12	168	222	221	112	161	258	140	12	70

Note

* Dimensions dependent on motor typ
(drawing: manufacture ABB).

All pump and motor sizes can be combined.

Other manufactures motors can be supplied on request.
Motor frame sizes are based on DIN 42673/677.

Motor-Pump Assemblies with SAE 1 1/2-Connection

KF 32... 80

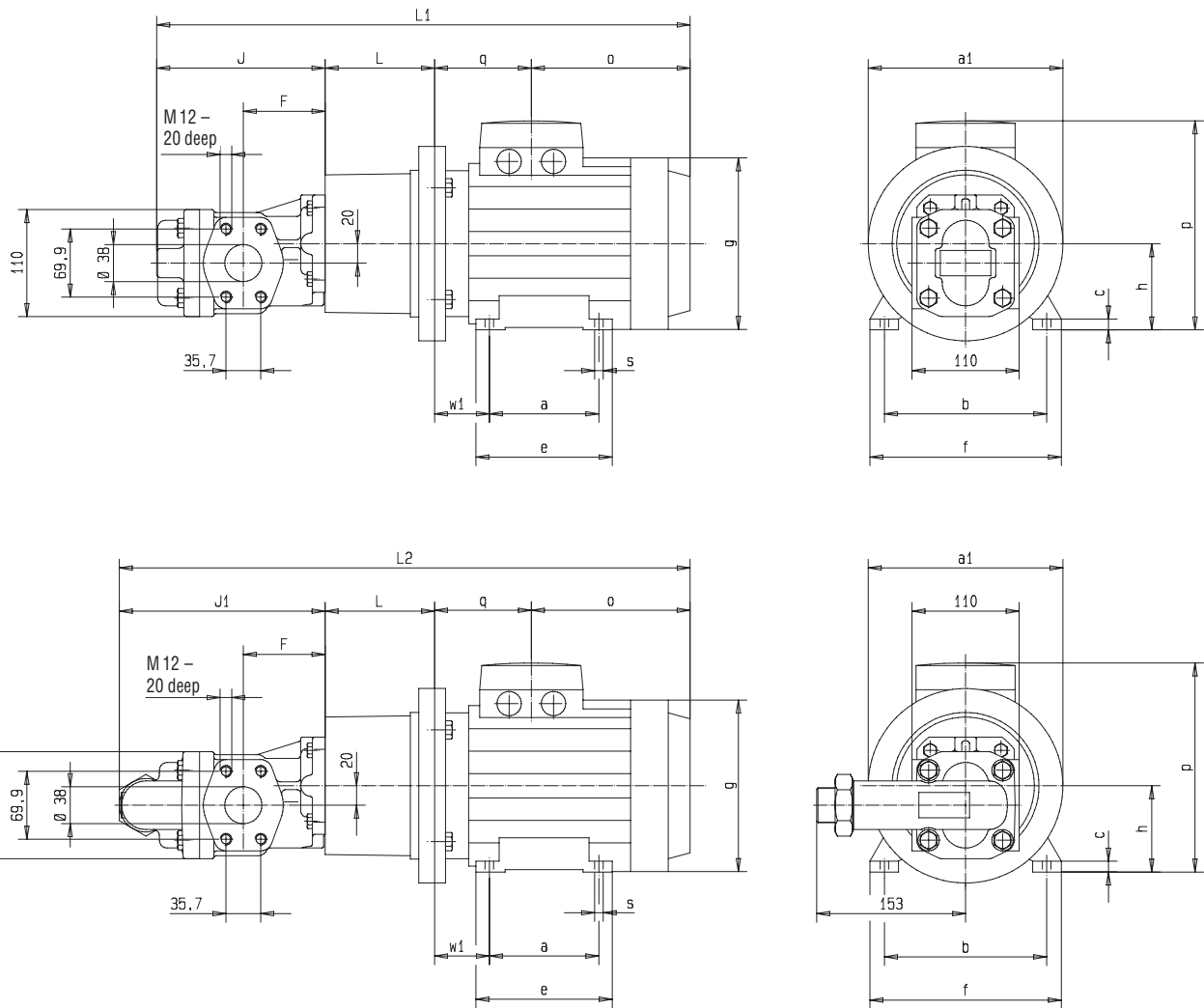

with pressure relief valve

KF 32... 80 Pump sizes

Nominal size	F	J	J ₁
32...50	84	173	212
63 / 80	100	208	247

Motor-Pump Assemblies with SAE 1 1/2-Connection

KF 32... 80

Frame size	Power Motor 6 pole		Power Motor 4 pole		Bell housing	Coupling	Total weight * kg	
	kW	1/min	kW	1/min			Nominal size 32...50 63...80	
80 S	0.37	920	0.55	1420	PT200-A-080-100	RA19/24-Z25/24-Z25/19	18.4	20.1
80	0.55	930	0.75	1420			19.4	21.1
90 S	0.75	930	1.1	1410	PT200-A-080-110	RA24-Z30/24-Z30/24	22.3	24
90 L	1.1	930	1.5	1420			25.3	27
100 LS	–	–	2.2	1430	PT250-A-080-124	RA24/28-Z30/24-Z30/28	31.3	33
100 L	1.5	950	3	1430			34.3	36
112 M	2.2	940	4	1435			37.3	39
132 S	3	960	5.5	1450	PT300-A-080-144	RA28/38-Z35/24-Z35/38	50	52
132 M	4	960	7.5	1450			58	60
132 M	5.5	955	–	–			64	66
160 M	7.5	975	11	1455	PT350-A-080-188	RA38/45-Z45/24-Z45/42	91	93
160 L	11	970	15	1460			105	107

* with pressure relief valve add, weight 1.8 kg

KF 32... 80 Dimensions

Frame size	Dimensions																	
	32...50 63...80				32 - 80													
	L ₁ *	L ₁ *	L ₂ *	L ₂ *	L	a ₁	a	b	c*	e*	f*	g*	h	o*	p*	q*	ø s*	w1
80 S	498	533	537	572	100	200	100	125	10	125	154	150	80	138	190	87	10	50
80	498	533	537	572	100	200	100	125	10	125	154	150	80	138	190	87	10	50
90 S	515	550	554	589	110	200	100	140	10	125	170	177	90	134	217	99	10	56
90 L	540	575	579	614	110	200	125	140	10	150	170	177	90	159	217	99	10	56
100 LS	586	621	625	660	124	250	140	160	12	172	197	197	100	187	237	102	12	63
100 L	586	621	625	660	124	250	140	160	12	172	197	197	100	187	237	102	12	63
112 M	598	633	637	672	124	250	140	190	12	168	222	221	112	161	258	140	12	70
132 S	684	719	723	758	144	300	140	216	14	212	262	261	132	216	296	151	12	89
132 M	684	719	723	758	144	300	178	216	14	212	262	261	132	216	296	151	12	89
160 M	854	889	893	928	188	350	210	254	20	288	310	310	160	299	370	194	15	108
160 L	854	889	893	928	188	350	254	254	20	288	310	310	160	299	370	194	15	108

Note

* Dimensions dependent on motor typ
(drawing: manufacture ABB).
Other manufactures motors can be supplied on request.
Motor frame sizes are based on DIN 42673/677.

All pump and motor sizes can be combined.

Motor-Pump Assemblies with SAE 2-Connection (Special No. 232)

KF 50...80

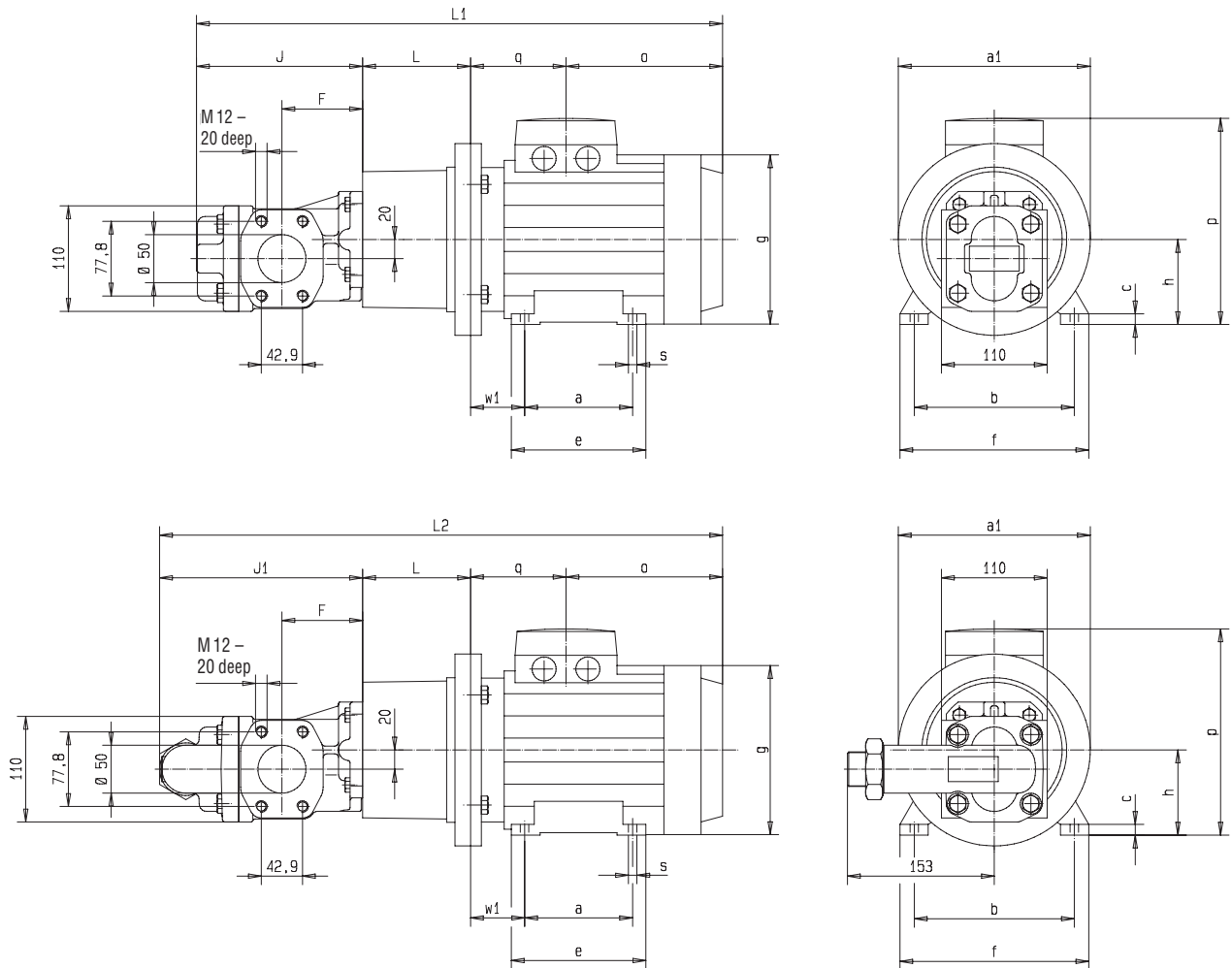

with pressure relief valve

KF 50...80 Pump sizes

Nominal size	F	J	J ₁
50...80	84	173	212
63 / 80	100	208	247

Motor-Pump Assemblies with SAE 2-Connection (Special No. 232)

KF 50... 80

Frame size	Power Motor 6 pole		Power Motor 4 pole		Bell housing	Coupling	Total weight * kg	
	kW	1/min	kW	1/min			Nominal size 32...50	63...80
80 S	0.37	920	0.55	1420	PT200-A-080-100	RA19/24-Z25/24-Z25/19	18.4	20.1
80	0.55	930	0.75	1420			19.4	21.1
90 S	0.75	930	1.1	1410	PT200-A-080-110	RA24-Z30/24-Z30/24	22.3	24
90 L	1.1	930	1.5	1420			25.3	27
100 LS	–	–	2.2	1430	PT250-A-080-124	RA24/28-Z30/24-Z30/28	31.3	33
100 L	1.5	950	3	1430			34.3	36
112 M	2.2	940	4	1435			37.3	39
132 S	3	960	5.5	1450	PT300-A-080-144	RA28/38-Z35/24-Z35/38	50	52
132 M	4	960	7.5	1450			58	60
132 M	5.5	955	–	–			64	66
160 M	7.5	975	11	1455	PT350-A-080-188	RA38/45-Z45/24-Z45/42	91	93
160 L	11	970	15	1460			105	107

* with pressure relief valve add, weight 1.8 kg

KF 50... 80 Dimensions

Frame size	Dimensions																	
	50...80 63...80				50 - 80													
	L ₁ *	L ₁ *	L ₂ *	L ₂ *	L	a ₁	a	b	c*	e*	f*	g*	h	o*	p*	q*	ø s*	w1
80 S	498	533	537	572	100	200	100	125	10	125	154	150	80	138	190	87	10	50
80	498	533	537	572	100	200	100	125	10	125	154	150	80	138	190	87	10	50
90 S	515	550	554	589	110	200	100	140	10	125	170	177	90	134	217	99	10	56
90 L	540	575	579	614	110	200	125	140	10	150	170	177	90	159	217	99	10	56
100 LS	586	621	625	660	124	250	140	160	12	172	197	197	100	187	237	102	12	63
100 L	586	621	625	660	124	250	140	160	12	172	197	197	100	187	237	102	12	63
112 M	598	633	637	672	124	250	140	190	12	168	222	221	112	161	258	140	12	70
132 S	684	719	723	758	144	300	140	216	14	212	262	261	132	216	296	151	12	89
132 M	684	719	723	758	144	300	178	216	14	212	262	261	132	216	296	151	12	89
160 M	854	889	893	928	188	350	210	254	20	288	310	310	160	299	370	194	15	108
160 L	854	889	893	928	188	350	254	254	20	288	310	310	160	299	370	194	15	108

Note

* Dimensions dependent on motor typ
(drawing: manufacture ABB).
Other manufactures motors can be supplied on request.
Motor frame sizes are based on DIN 42673/677.

All pump and motor sizes can be combined.

Accessory Connections

Threaded Flange G-SAE 3/4

Weight 0.39 kg – N
 – F
 – P

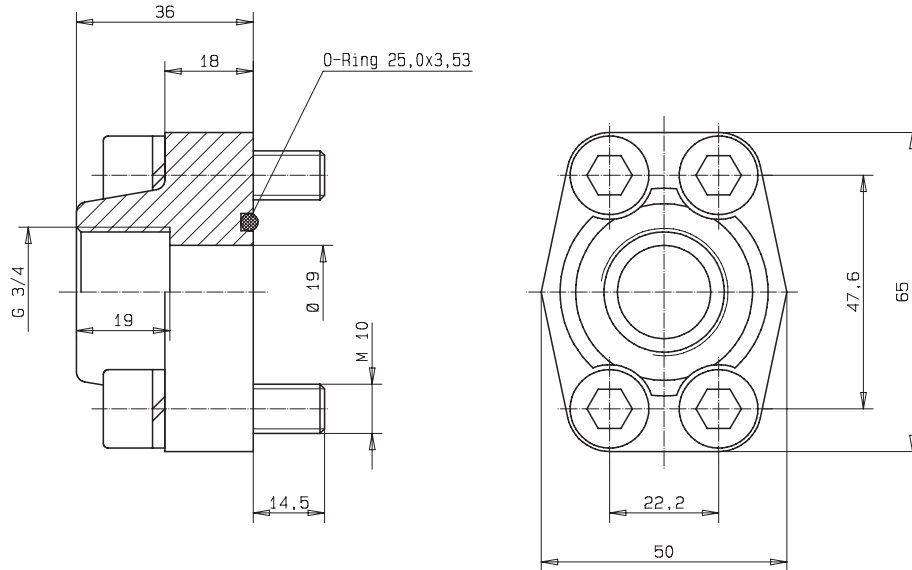

Welding Flange S-SAE 3/4

Weight 0.39 kg – N
 – F
 – P

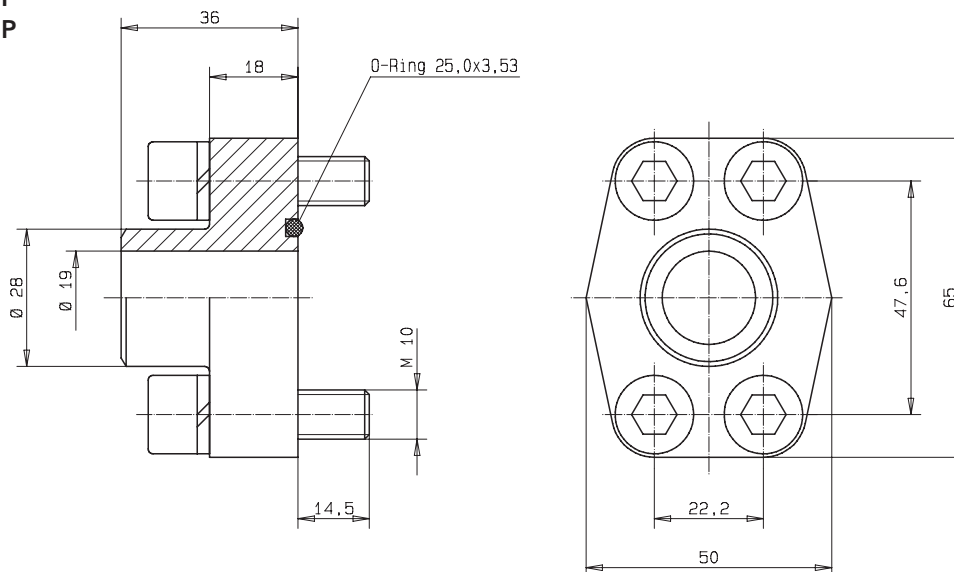

N = NBR O-Ring
 F = FKM O-Ring
 P = PTFE O-Ring

Accessory Connections

Threaded Flange G-SAE 1

Weight 0.46 kg – N

– F

– P

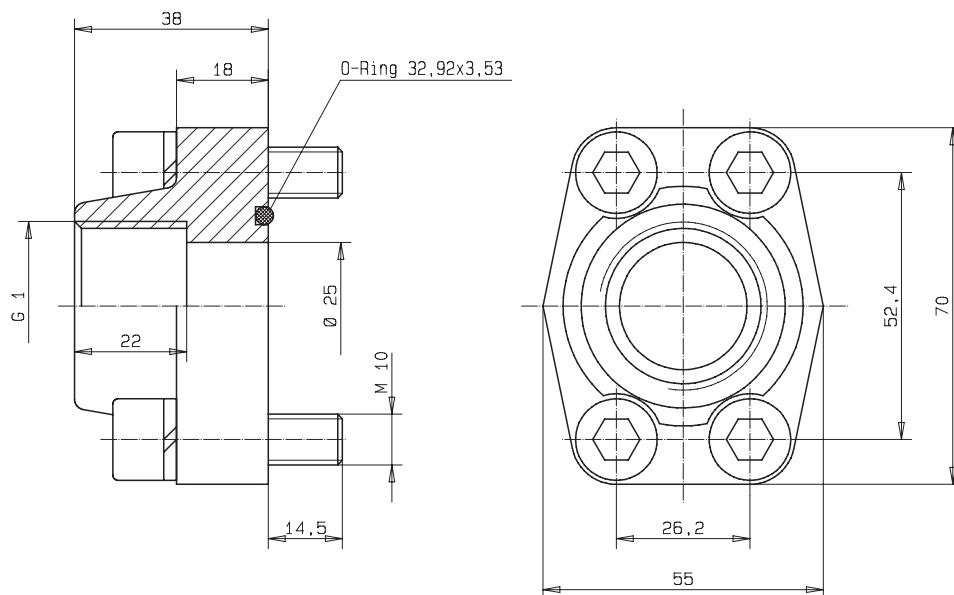

Welding Flange S-SAE 1

Weight 0.46 kg – N

– F

– P

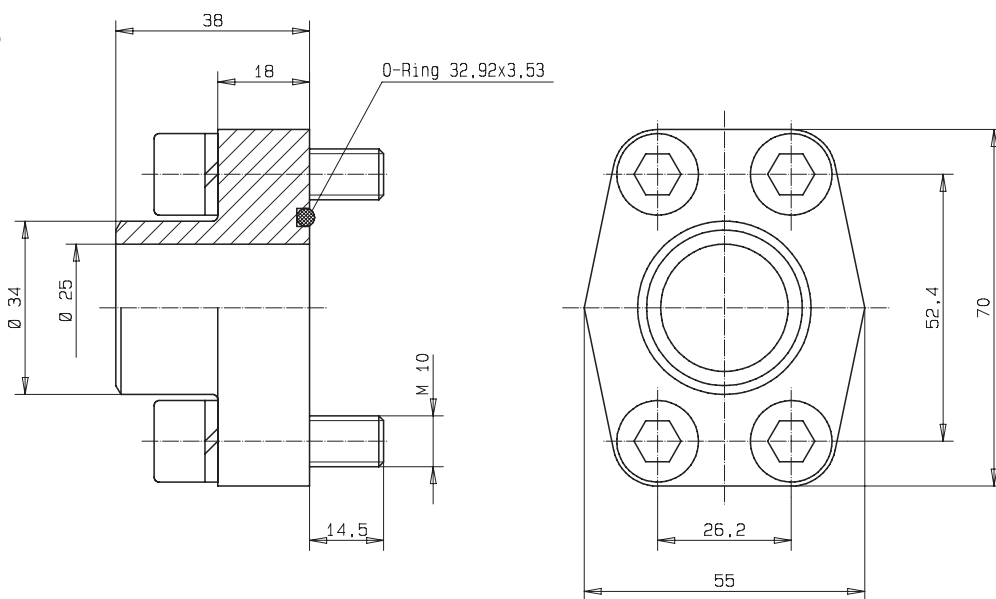

N = NBR O-Ring

F = FKM O-Ring

P = PTFE O-Ring

Accessory Connections

Threaded Flange G-SAE 1 1/2

Weight 1.05 kg – N
 – F
 – P

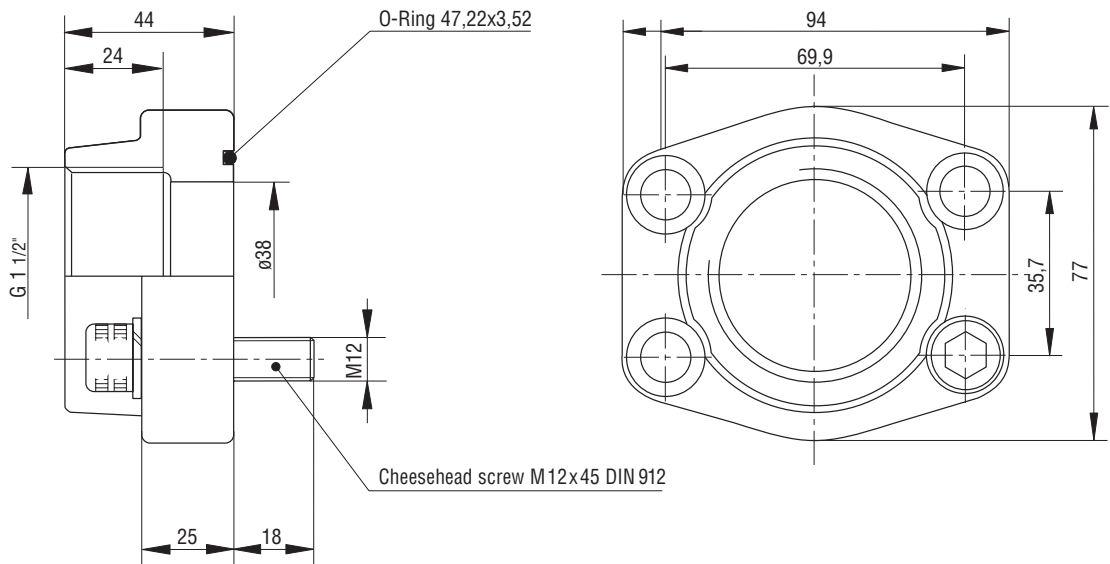

Welding Flange S-SAE 1 1/2

Weight 1.05 kg – N
 – F
 – P

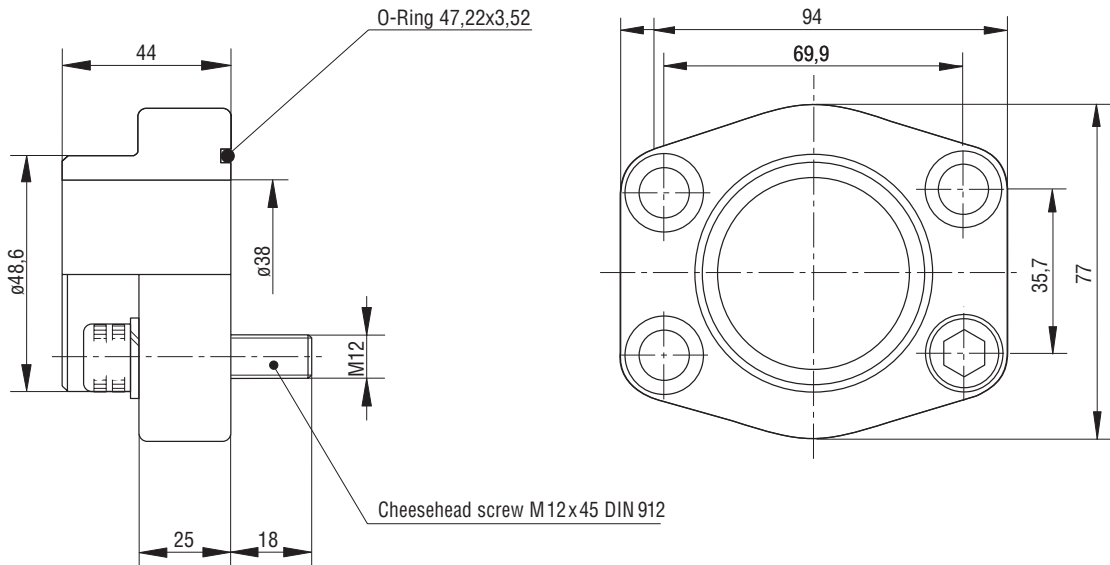

N = NBR O-Ring
 F = FKM O-Ring
 P = PTFE O-Ring

Accessory Connections

Threaded Flange G-SAE 2

Weight 1.19 kg – N

– F

– P

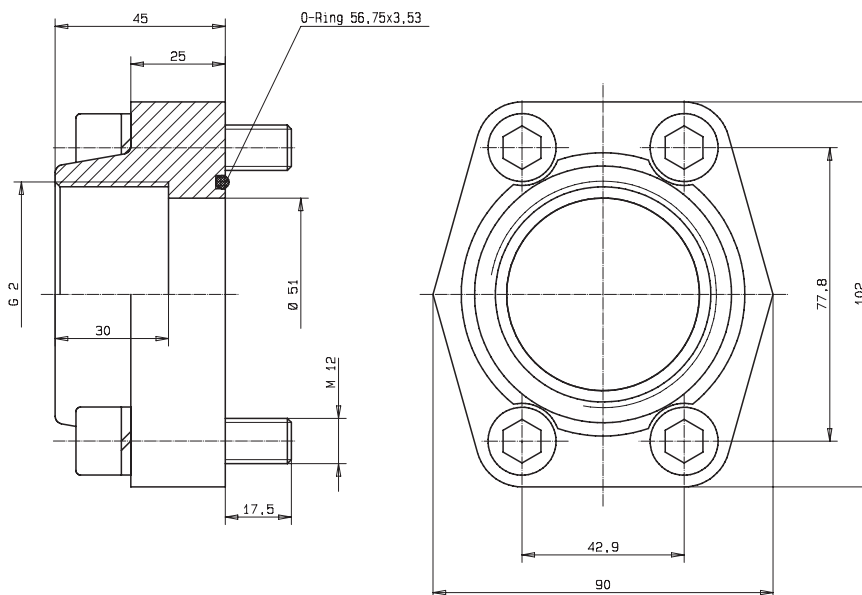

Welding Flange S-SAE 2

Weight 1.19 kg – N

– F

– P

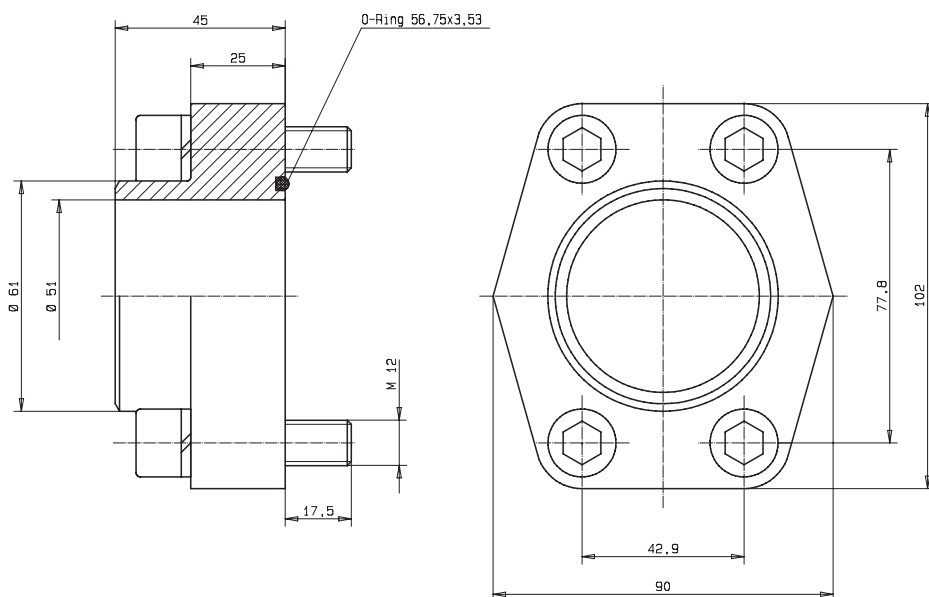

N = NBR O-Ring

F = FKM O-Ring

P = PTFE O-Ring

Accessory Liquid Seal

Tank for liquid seal liquids

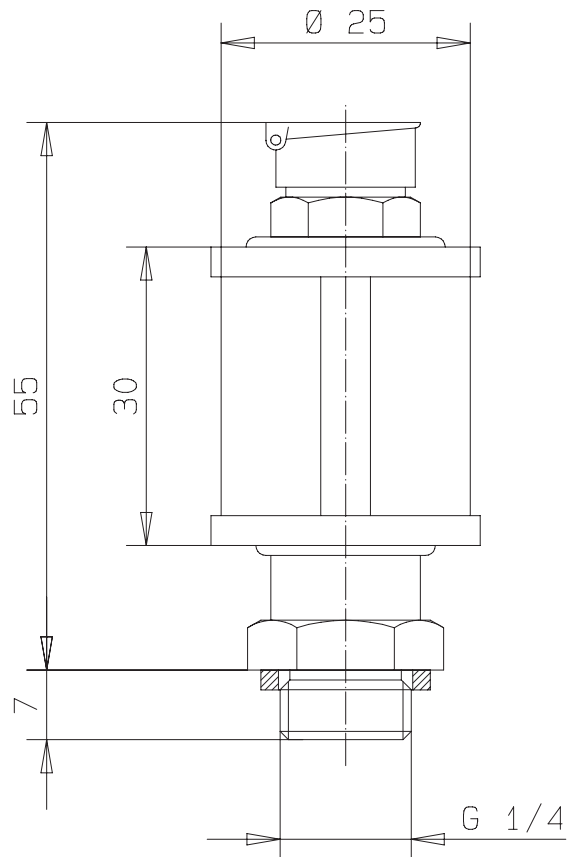

Adapter for screw size tap G 1/8

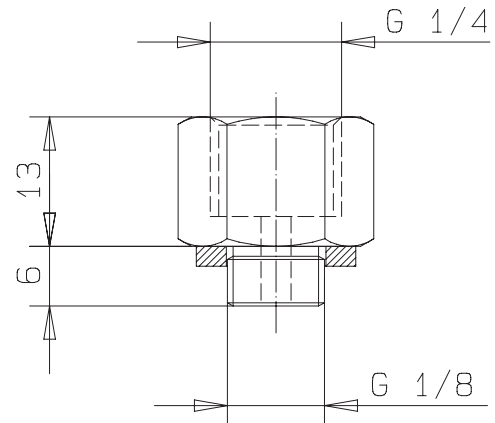

Product Portfolio

Transfer Pumps

Transfer pumps for lubricating oil supply equipment, low pressure filling and feed systems, dosing and mixing systems.

Mobile Hydraulics

Single and multistage high pressure gear pumps, hydraulic motors and valves for construction machinery, vehicle-mounted machines.

Flow Measurement

Gear and turbine flow meters and electronics for volume and flow metering technology in hydraulics, processing and laquering technology.

Industrial Hydraulics / Test Bench Construction

Cetop directional control and proportional valves, hydraulic cylinders, pressure, quantity and stop valves for pipe and slab construction, hydraulic accessories for industrial hydraulics (mobile and stationary use).

Technology Test benches / Fluid Test benches.



KF4...80/GB/05.08

KRACHT